

**DEVELOPING APPROPRIATE TECHNOLOGY AND ESTABLISHING
A PLANT FOR ACTIVATED CARBON PRODUCTION FROM
COCONUT SHELLS FOR COMMUNITY BASED ORGANISATIONS**

T. K. DHAMODARAN



KSCSTE - KERALA FOREST RESEARCH INSTITUTE

Peechi - 680 653

Thrissur, Kerala,

India



May 2019

**DEVELOPING APPROPRIATE TECHNOLOGY AND ESTABLISHING A PLANT FOR ACTIVATED
CARBON PRODUCTION FROM COCONUT SHELLS FOR COMMUNITY BASED ORGANISATIONS**

(Final Report of Project KFRI 559/'08)

(Project funded by ICAR-NAIP)

T. K. Dhamodaran
Chief Scientist & Head



**Wood Science and Technology Division
KSCSTE-Kerala Forest Research Institute
Peechi - 680 653
Kerala, India**



May 2019

1. OUTLINE OF THE PROJECT PROPOSAL

1. Project Number: KFRI 559/'08
2. Title of Project: Developing appropriate technology and establishing a plant for activated carbon production from coconut shells for community based organisation

(Component - II of the ICAR-NAIP "Value Chain in Coconut" Project coordinated by CPCRI)
3. Principal Investigator: Dr. T. K. Dhamodaran, Scientist F (Wood Science & Technology)
4. Objectives:
 - i. Develop an up-scaled improved plant appropriate for community level production of charcoal and activated carbon from coconut shell by designing, fabricating and installing a continuous vertical carbonizer for pollution-free production of charcoal and a horizontal Rotary Fluidized Bed Reactor (RFBR) charcoal activation plant for demonstration and commercialization of the concept of community level production of charcoal and activated carbon for industrial use
 - ii. Assess the yield and quality of charcoal and activated carbon.
 - iii. Optimize reaction conditions for the production of desired quality products.
5. Funding Agency: ICAR-NAIP
6. Budget Outlay: 91.67 Lakhs
7. Duration: 2008 December - 2014 June
8. Programme Outline:
 - i. Identify appropriate technology, design, fabricate and install pilot plant appropriate to community level production of charcoal and activated carbon.
 - ii. Trial production of charcoal and activated carbon for the identification of optimized reaction conditions for desired quality products through the assessment of yield and quality of products.

2. ACKNOWLEDGEMENTS

Thankfully acknowledging the technical and research inputs and helps of Dr. S. Babu and Engr. K. N. Arun Raj, Senior Research Fellows worked in the project. Sincere thanks are due to Dr. R. Gnanaharan and Dr. K.V. Sankaran, Ex. Directors of KFRI; Dr. George V. Thomas, Ex. Director, CPCRI; Engr. K. Madhavan, Consortium Principal Investigator & Principal Scientist (Rtd.), CPCRI for encouragements and Dr. P.S.R. Babu, and Engr. Suresh Kumar, Partners, Global Carbon Tech, Erode, Tamil Nadu for successful fabrication and installation of the newly developed plants. Acknowledgement is also due to the present Director of KFRI, Dr. Syam Viswanath. Also, sincerely acknowledging the technical helps of Dr. T. M. Ganesh Gopal and Shri. . V. Vigesh, Project Fellows and Engr. Jino Johny, KFRI for mechanical engineering consultations and machine drawings during the last phase. Financial support from the NAIP-ICAR is gratefully acknowledged, without which the project could not be taken up.

3. CONTENTS

Sl. No.	Topics	Page No.
1	Outline of the Project Proposal	1
2	Acknowledgements	2
3	Contents	3
4	Preface	4
5	Abstract	5
6	Introduction	6
6.1	Rationale of community level processing	6
6.2	Appropriate technology for cluster or community based organisations	6
6.3	Continuous carbonization pilot plant appropriate to community level production of	7
6.4	Activated granular shell carbon from charcoal	7
6.5	Appropriate technology for community level production of activated charcoal - Improving the Fluidized Bed Reactor (FBR) system developed to Rotary Fluidized Bed Reactor System (RFBR)	8
7	Review of Literature	9
7.1	Charcoal	9
7.2	Activated Carbon	9
7.3	Uses of Activated carbon	9
7.4	Raw material	10
7.5	Advantageous properties of coconut shell activated carbons	10
7.6	Manufacturing methods	11
7.7	Economics for sustainability	12
8	Materials and Methods	13
8.1	Charcoal Production Plant: Development of a Continuous Vertical Carbonizer	13
8.2	Description of the carbonizing plant with coconut shell dryer	13
8.3	Engineering drawing of continuous vertical carbonizing charcoal plant	15
8.4	Detailed Engineering drawings of the main components of the carbonizing plant	16
8.5	Layout of the carbonizing plant	20
8.6	Activated Carbon Production Plant - Development of a Rotary Fluidized Bed Reactor	23
8.7	Engineering design drawing of the Rotary Fluidized Bed Reactor (RFBR) Activation Plant	24
8.8	Description of the RFBR	25
8.9	Detailed Engineering drawings of the main components of the RFBR Activation Plant	26
8.10	Photographs of some of the main components of the RFBR Activation Plant	29
8.11	Photographs of work shed & plants	31
8.12	Assessment of Yield and quality of products	33
8.12.1	Methods of charcoal quality analysis	33
8.12.1.1	Determination of moisture content	34
8.12.1.2	Determination of volatile content	34
8.12.1.3	Determination of ash content	34
8.12.1.4	Determination of Fixed carbon content	34
8.12.1.5	Determination of Iodine value	34
8.12.2	Methods of Analysis of Activated carbon	35
8.12.2.1	Materials	35
8.12.2.2	Methods	35
8.12.2.2.	Determination of moisture content	35
8.12.2.2.	Determination of ash content	35
8.12.2.2.	Determination of Iodine value	35
8.12.2.2.	Determination of surface area	35
9	Results and discussion	36
9.1	Operation of the Charcoal Plant	36
9.2	Charcoal quality	37
9.3	Operation of Activation Plant	38
9.4	Quality of Granular Active carbon produced in the newly developed RFBR Activation	39
10	Conclusions	40
11	Summary	41
12	References	42

4. PREFACE

Coconut by-product utilization through value addition should be an integral part of any coconut based industry for sustenance and better livelihood of the coconut farmers, members of coconut based agricultural cooperative societies, workers and industries. Utilization of coconut shells, a ligno-cellulosic wood material, is an area warranting much research inputs from wood technologists. Conversion of shells into charcoal is a promising area of value addition with low-energy inputs, but requiring intensive research for developing clean technologies. Conversion of shell charcoal into activated carbon is an area where still many-fold value addition potential exists; but this field being under the monopoly of large-scale industries, attempts for down-scaling the technologies or developing appropriate technologies become the need of the hour when cluster or community based organization level of operation are attracting much attention. It is in this context, KFRI was able to develop upscaled versions of a pollution-free continuous vertical carbonization plant for charcoal production and an innovative rotary fluidized bed reactor activation plant appropriate to community level operation. An earlier project by the financial support of the Coconut Development Board laid the foundation of conceptualizing the pilot plants in this line. The present project funded by the ICAR-NAIP, is a follow up of the earlier project to further upgrade and up-scale the design of the plants to strengthen demonstration for commercialization of the technologies developed. Any attempt in this line will help to achieve livelihood improvement of the poor and marginalized coconut farmers and better profit to coconut based industries.

The collaborative consortium mode project with CPCRI resulted in the installation of the up-scaled plants at the project site in CPCRI, Kasaragod, Kerala is ready for demonstration and production. The technologies developed through this project are of timely importance and are readily transferable to industrial entrepreneurs. Requests for transfer of technology for taking up commercialization will always be welcomed by the Institute.

Dr. Syam Viswanath
DIRECTOR
KFRI

5. ABSTRACT

Coconut shells, a ligno-cellulosic woody material, offers an excellent raw material for the value added product, shell charcoal, an important industrial product and raw material for production of further value added product, activated granular shell carbon. Traditional shell charcoal production by the existing earth pit earth and drum methods are highly air polluting due to ground level smoke spread. Charcoal production in the cluster or community level offers an additional livelihood to coconut farmers and the rural poor. As the existing method of industrial scale production of activated carbon being the rotary kiln method which has very little scope for down-scaling due to techno-economic considerations, fluidized bed reactor (FBR) system was identified as the appropriate technology for small or community level production of active carbon. It was in this context, that the Kerala Forest Research Institute (KFRI) developed an appropriate clean technology to produce charcoal and physically (steam) activated granular shell carbon at the cluster or community level in an earlier project funded by the Coconut Development Board (CDB). The present work aimed at further upgrading the technology and up-scaling the capacity of the plants (charcoal plant and activation plant) developed so as to further appropriate the technology for adoption in small to medium scale coconut-based industrial enterprises for their sustainable survival. The present study forms a component, “Developing viable processing technologies and machineries to produce activated coconut shell charcoal” of an integrated project on “Value Chain in Coconut” supported by the NAIP-ICAR.

Both the charcoal production and activation plants are designed for continuous operation by way of operating three shifts per day. The design of the pollution-free continuous vertical carbonizing plant is with an input capacity of 3 tons raw material (coconut shell) per day developed by KFRI was up-scaled to an input capacity of 6 tons per day and further improved technically by incorporating a shell drier for pre-drying the raw material. The shell drier is designed for fitting above the carbonizer hood so that only dried shell will enter into the charcoal plant. This facilitates the use of shells with higher moisture content during the rainy season. The plant is successfully designed for a targeted charcoal yield of around 30 per cent.

The design of the vertical fluidized bed reactor (FBR) activation plant with an input capacity of 0.3 ton shell charcoal per day developed by KFRI was further improved to a horizontal rotary fluidized bed reactor (RFBR) for taking the technical benefit of high quality product coupled with cost effectiveness; the input capacity was up-scaled to 2 ton shell charcoal per day, targeted for the standard (50%) active carbon yield. Both the upgraded plants were successfully designed; fabricated, installed at the CPCRI campus in Kasaragod, Kerala and trial runs were conducted. The process parameters were optimized for desired quality products and assessed the quality of products for industrial use. It was found that products from both the plants (shell charcoal and activated granular shell carbon) conform to the specifications of Indian Standards. The design drawings, description and operational details of the newly developed design upgraded up-scaled plants were documented. Both the plants are ready for further demonstrations to potential entrepreneurs and for use of the Community Based Organizations (CBOs). The technologies are ready for commercialization. The details of the plants developed as well as the results of quality assessments are given in this report.

Economic analysis showed that a system which can process 6 tons of shells per day is financially viable for self-sustaining and accordingly the earlier pilot plant designs were up-scaled for an input capacity of 6 tons of shells per day. As far as technical viability is concerned, scope exists for further improvements for automation for both the carbonization and activation plants. Further scope also exists for developing appropriate technology for the CBO level production of impregnated active carbons for speciality purposes (*e.g.* silver impregnated granular active shell carbon) from the RFBR high grade active carbon produced.

Both the pollution-free plants developed are techno-economically appropriated for cluster or community level production of charcoal and activated carbon.

Key words: Coconut shell; shell charcoal; charcoal plant; activated carbon; activated carbon plant.

6. INTRODUCTION

Coconut shells, a ligno-cellulosic woody by-product of kernel based copra processing units, available in considerable quantities, is the raw material for the value added products, charcoal and activated granular shell carbon. Shell charcoal is the basic raw material for the further value-added product, activated granular shell carbon, an industrial adsorbent of great demand in the domestic as well as in the export market. Shell charcoal is traditionally produced at the rural level by employing the traditional earth pit and portable drum methods, which are highly polluting due to ground level smoke spread adversely affecting public health. Value addition to coconut shell charcoal by converting it into activated carbon, is presently limited to monopolized large-scale industrial units by the traditional rotary kiln method. The Kerala Forest Research Institute (KFRI) made it possible to downsize the production of activated carbon from large scale industries to suitable for operation at community level by designing appropriate pollution-free continuous vertical carbonization plant for charcoal production and fluidized bed reactor (FBR) activation plant for the production of granular active shell carbon (Dhamodaran and Gnanaharan 2008).

6.1. Rationale of Community Level Processing

The concept of community or cluster level processing of coconut received momentum following the implementation of various women empowerment schemes. Economic viability of community level processing units in the coconut sector is realized from various programmes and schemes implemented by State and Central Government agencies. Conversion of shells to charcoal and subsequent conversion of the charcoal produced into activated granular carbon opens up an avenue for community level processing for value addition of these by-products of coconut-based industries. Activated carbon being a high value-added product from charcoal and charcoal being the single raw material required for manufacturing active carbon, rather than selling the charcoal produced, scope exists for the cluster or community to use it for the production of further value-added product, activated carbon, in the cluster itself.

6.2. Appropriate Technology for Cluster or Community Based Organisations (CBOs)

Cluster or community based organisation (CBO) approach is popular now days in the small scale industries. In clusters, charcoal is presently produced in small quantities by the traditional polluting earth pit or drum methods; attempts for designing small chimneys for the pit or drum was not significantly successful to control pollution; as there is always limitation to the height of chimney due to stability issue. The charcoal produced in a cluster could be pooled together for further marketing or processing. Changing the charcoal production from the cluster members' homesteads to a community level operated centralized production unit having alternative safe and clean production facility thereby limiting the cluster members' activity to collection of the raw material alone will greatly help to solve the issue of environmental damage. Further, products of desired quality fetching higher prices and enhanced production can be assured in such controlled systems.

Activated carbon manufacturing industry is presently limited to the large-scale sector. The technology available is limited to the widely adopted rotary kilns of large scale industries. Rotary kilns are commercially available in large sizes only and hence are of not suitable for the proposed approach for use in cluster-based industries in a small scale. Down-scaling the rotary kiln into required size is also difficult and uneconomical due to its inherent issues of minimum length and diameter associated with the required minimum retention or residence time of charcoal for activation in the kiln and the non-suitability of such a system to process small quantity of charcoal available from the cluster. It is in this context, it was planned to develop an appropriate technology

for community level production of activated carbon from charcoal as it forms a part of the integrated coconut utilization value chain is concerned. Further, this will provide the farmer's cluster an opportunity to get enhanced income through local community or cluster level processing for further value-addition. This will help the farmers to sustain and to retain cultivation affordable. Industries will also get benefited in terms of new technology for small scale production and in terms of value-added product, activated carbon.

Realizing the need to identify and develop appropriate processing methods for value addition of coconut by-products such as shells, suitable for community level operation so as to enable the rural community also to realize the benefit of value addition, the Kerala Forest Research Institute (KFRI) undertook a project supported by the NAIP-ICAR of the Government of India in this regard to upgrade their already developed appropriate clean technologies for the production of charcoal and activated carbon from coconut shells at the community level for industrial use by designing, fabricating and installing upgraded plants for demonstration, training and small scale production for livelihood improvement of potential coconut-based industrial entrepreneurs.

6.3. Continuous Carbonization Pilot Plant Appropriate to Community Level Production of Charcoal

Developing a pollution-free industrial carbonization plant is the only solution to overcome the existing constraints of pollution and, low yield and quality in traditional charcoal manufacturing. Batch process is not ideal for heat efficiency or recovery and for pollution control. For better pollution control, a continuous carbonization plant of limited capacity is appropriate to community level operation and management. Introduction of tall chimney in such a system with a facility for flaring the volatile gas evolved (during the stabilized continuous carbonizing phase) in the chimney top can avoid the ground level smoke or volatile vapours spread. In a continuous carbonization plant smoke emission will always be limited to the starting stage and when once the burning process is stabilized and continuous there will not be any smoke emission. Whatever volatile vapours emitted during the continuous and stabilized carbonizing phase will get flared in the chimney top. Introduction of heat recovery system can facilitate the recovered heat for use in copra drying. Proper designing of the carbonization kiln can take care of the air inlet and out let controls for desired quality product. Control over the carbonization temperature can lead to better yield also. In the above context, it was planned to improve the design of the continuous carbonization pilot plant with an input capacity of 1 ton shell per shift of 8 hours, which can process 3 tons shell per day developed by KFRI (Dhamodaran and Gnanaharan 2008) to an input capacity of 6 tone shell per day and to fabricate and install the plant for the benefit of further commercialization efforts.

6.4. Activated Granular Shell Carbon from Charcoal

Industrial production of granular shell carbon from shell charcoal is currently limited to employing rotary kilns. Physical activation is achieved using superheated steam at a pressure of around 3 kg/cm² and temperature around 900⁰ C. A quantity of steam of 1.5 times the weight of charcoal is required for effective activation. Industrial rotary kilns for activation of charcoal require the minimum size specifications of 12-18 metre length, 2.5 to 3 metre diameter and a shell thickness of 12-20 mm. The minimum coast of such a plant is estimated to be around Rs. 2 crores (in 2008). Further, in the rotary kiln, activation takes a minimum residence time of 10-15 hours. These size specifications and proportionate minimum quantity of charcoal required for a charge being large and prolonged residence time required makes the system uneconomical to downscale for community level operation where only limited quantity is handled. Financial investment required for rotary kiln is unaffordable to community scale set up.

6.5. Appropriate Technology for Community Level Production of Activated Charcoal - Improving the Fluidized Bed Reactor (FBR) System Developed to Rotary Fluidized Bed Reactor System (RFBR)

Fluidized bed reactor (FBR) system is identified as an alternative and cost effective method for production of granular active carbon suitable for liquid phase applications. FBR are known for rapid heat transfer resulting in high conversion rates. Absence of moving parts in FBR contributes to low maintenance cost. The reactor is placed in a furnace with three heating zone that can be operated up to 1100^o C. In an FBR, fine particle reactant is locally suspended in the fluidized bed by blowing a gas stream upward through the bed to ensure a good contact between solid and gas reactants. The fluidized bed consists of a fluid - solid mixture that exhibits fluid- like properties. The bed can be considered to be an inhomogeneous mixture of fluid and solid that can be represented by single bulk density.

The fluidized bed is formed when a quantity of solid particulate substance is placed under appropriate conditions to cause the solid / fluid mixture to behave as a fluid. This is usually achieved by the introduction of pressurized fluid through the particulate medium. This results the medium then acquiring properties and characteristics of normal fluids; such as the ability to free flow under gravity or to be pumped using fluid type technologies. The main application of the fluidized beds is in technical processes requiring high level of contact between gasses and solids. Area contact between fluid and solid per unit bed volume is extremely high in this system. Also, this system facilitates high level of intermixing of the particulate phase.

Uniform particle mixing and temperature gradients, ability to operate in continuous state are the main advantages of FBR. Current understanding of actual behaviour of materials in a fluidized bed is rather limited. It is very difficult to predict and calculate the complex mass and heat flow within the bed. Due to this lack of understanding, new processes require designing specific pilot plants and due to this reason, FBRs are seldom used in large scale active carbon industry, as the rotary kilns are time-proven.

An FBR pilot plant with an input capacity of 0.3 tone charcoal per day developed by KFRI (Dhamodaran and Gnanaharan 2008) was planned to upgrade its design to a rotary FBR (RFBR) for incorporating the benefits of the rotary kiln system and to increase its input capacity to 2 tones charcoal per day; and to fabricate and install the plant for demonstration and strengthening community or cluster level operated coconut-based CBOs.

It was in this context, with the financial support from the National Agricultural Innovation Project (NAIP) of the Indian Council of Agricultural Research (ICAR), a further innovative programme for designing, fabricating and installing a pollution-free shell charcoal production plant with an input capacity of 6 tons shell per day and an improved and upgraded version of the FBR activation plant with an input capacity to consume the entire charcoal thus produced from the vertical continuous carbonization plant was planned. The project was planned to create a facility for demonstrating the potential of value addition of coconut shell charcoal by way of establishing a technically and capacity wise upgraded pollution-free charcoal plant and fluidized bed reactor plant for charcoal activation.

7. REVIEW OF LITERATURE

7.1. Charcoal

Majority of the charcoal production methods reported in literature are batch types causing smoke pollution (Foley 1986). Out of the various studies reported on the yield of coconut stem wood charcoal production (Richolson and Alston 1997, Palomer 1979, Estudillo *et al.* 1977), the study from the Kerala Forest Research Institute (Gnanaharan, *et al.* 1988) reported a maximum yield in the range of 26-29%. Pollution-free charcoal production is possible only through continuous carbonization kilns; the design of a typical pilot plant capable to produce coconut shell charcoal as per Indian Standards (BIS 1992) is reported by Dhamodaran and Gnanaharan (2008). A pollution-free continuous vertical carbonization pilot plant of 1 ton output capacity per shift of 8 hours (*i.e.*, 3 tonnes input capacity per day) is designed, fabricated and installed as (Fig. 1) is found capable of producing shell charcoal with a volatile content of 13%, ash content of 1.0-1.5%, and fixed carbon content of 86% suitable for industrial use as per the Indian Standards (BIS 1992) and a superior yield of more than 30% was achieved.

Out of the various resources for charcoal production, coconut shell remains to be the best due to its inherent superior qualities like hardness, porosity, yield, etc. Again, out of the various uses of charcoal, such as cooking fuel, gun powder, explosives and pyrotechnic compositions; its wider demand is for the production of granulated activated carbon, a major industrial chemical adsorbent.

7.2. Activated Carbon

Activated carbon is a group of industrial adsorbent material with highly developed internal surface area and porosity (microcrystalline porous carbon matrix with pore diameter range of <2 nm to > 50 nm with large internal surface area to the extent of 400 - 3000 m^2/g as measured by the nitrogen BET method and adsorption volumes of 0.2 - 0.8 cm^3/g depending on activation conditions), and hence a large capacity for adsorbing chemicals from fluids; produced by pyrolysis and activation of carbonaceous natural as well as synthetic precursors.



Fig. 1. Carbonizing pilot plant: An overall view

Activated carbon has the strongest physical adsorption forces or the highest volume of adsorbing porosity of any material known to mankind. Figuratively speaking, 5 g of activated carbon can have the surface area of a football ground. McDougall (1991), Manocha (2003) and Clements (2002) gave a brief overview of the granular activated carbon (GAC) production and application technologies.

7.3. Uses of Activated Carbon

As far as the uses of Activated carbon is concerned, they are used as adsorbents in liquid phase uses such as removal of taste, odour, colour, haze, colloids, surfactants, pesticides, and other organics; whereas it has the adsorbent applications in gas phase such as separation of gases from gas mixtures, separation of vapours from gases, and as catalyst support. Among specific applications, removal of odour, colour, taste and other undesirable organic impurities from potable water in the

treatment of domestic and industrial waste water, solvent recovery, air purification in inhabited spaces such as restaurants, theatres, food processing and chemical industry, for removal of colour from various types of sugar syrups, in air pollution control, in purification of many chemicals, pharmaceuticals and food products, and a variety of gas phase applications, in gold recovery from mines, etc., are some important areas where active carbon finds applications. Activated carbon is widely used for adsorption of pollutants from gaseous and liquid streams. Use of porous carbons for automobile canisters to adsorb gasoline vapour and the use of activated carbon fibres (ACF) for energy applications such as adsorbed natural gas (ANG) storage containers as an alternative to compressed natural gas (CNG), ACF for more efficient electric double-layer capacitors in rechargeable batteries, etc., are some of the recently developed applications of specialty grade active carbons (Manocha 2003). Activated carbon is non-toxic, used medicinally to adsorb a wide variety of toxins; doses to the extent of 1g/body weight are routinely given in human poisoning cases. Activated carbon will not have any detrimental chemical interactions with any other chemicals that would be used in organic food processing (Cooney 1980). About 190 process patents and various applications of activated carbon are summarized by Yehaskel (1978).

7.4. Raw Material

As far as the raw material for activated carbon production is concerned, it can be made from any substance containing high carbon content such as bituminous coal, lignite, and petroleum coke, and biomass resources such as coconut shells, wood, saw dust, peat, bagasse (Loannidou and Zabaniotou 2006), and animal residues such as bone. The moisture content of the raw material is an important parameter; if it is high (>20%), the water driven off during the early stages of pyrolysis or carbonization, reacts with the off-gases or impedes their removal which allows the off-gases to crack and restrict micro-pore openings in the product (Stephen, *et al* 1992). The nature of the source material has marked effect on properties such as hardness and pore-size distribution of the final product. The activated carbon production challenge is thus to make tailor made product to precisely suit each applications or range of applications by optimizing production parameters to control the reactions for desired quality product.

7.5. Advantageous Properties of Coconut Shell Activated Carbons

Coconut shell activated carbons have the advantages over carbons made from other materials because of its high density, high purity, and virtually dust free nature. These carbons are harder and more resistant to attrition; besides being amorphous that can absorb many gases, vapours, liquid impurities and colloidal solids. The most important characteristic of activated coconut shell carbon is that it is extremely micro-porous, around pore diameter of 20 Angstrom. For this reason, coconut shell active carbon is ideal for the adsorption of small gaseous molecules that fit snugly into the micro-pores, and are therefore extensively employed in gas-phase and solvent recovery applications. The extremely good impact hardness and wet abrasion resistance of coconut shell active carbon combined with their high adsorptive capacity for the small gold dicyanoaurate complex, makes these carbons ideal for applications in gold recovery.

The structure of pores and the pore-size distribution are predetermined to a large extent by the source material, if it is of lingo-cellulosic origin, which is apparent from the photomicrographs of the pore structure of activated carbons manufactured from coconut shells (McDougall and Hancock 1980). This indicates that the structure of the original source material, *viz.*, the cellular structure of the coconut shell is still present in the carbon skeleton of the final product. Therefore, the inherent cellular structure of raw materials of vegetable origin imposes a constraint on the extent to which the properties of the product can be modified for special applications. For example, the micro-pores

of the cellular structure of coconut shell can be converted into macro-pores by burning-away the cell walls, thus changing the adsorption properties of the final product. But, unfortunately this type of modification is always accompanied by a loss in the structural integrity and, hence, the strength of the product, as well as a decrease in product yield.

Surface area of granular coconut shell active carbon, as measured by the N₂ BET adsorption, is proportional to the degree of burn-off to a certain point (around 50%), and this point corresponds to the formation of micro-porosity in the product. The point after which further burn-off results in reduction of BET surface area represents the conversion of micro-pores into meso-pores and macro-pores by the burning-away of the pore walls. This will be usually associated with a loss in the structural strength of the product (McDougall 1991).

7.6. Manufacturing Methods

Laine *et al* (1991) prepared coconut shell activated carbon in a small scale rotary kiln at 800^o C and found that the product surface area increased with increasing the water input concentration from about 0.5 to 5.0 g/g of feed, resulting surface area values up to 1,400 m²/g. The use of nitrogen instead of air during activation did not significantly change product surface area.

The manufacture of high-quality activated carbon products from lingo-cellulosic origin is a difficult task because of the number of variables involved in the manufacturing process and the complex interrelationship between those variables. The prime objective in the manufacture of granular active carbon from coconut shell is the development of an optimum pore structure associated with a high surface area - with minimum loss of the carbon content through carbonization and oxidation - and of a product with sufficient structural strength to withstand normal usage without excessive attrition of the particles. This warrants the serious attention towards employing scientific methods based on latest developments in the field.

Satya Sai et al. (1997) produced activated carbon from coconut shell car using steam or carbon dioxide as the reacting gas in a 100 mm diameter fluidized bed reactor. The effect of process parameters such as reaction time, fluidizing velocity, particle size, static bed height, temperature of activation, fluidizing medium and solid raw material on activation is studied. The product is characterized by determination of iodine number and BET surface area. The product obtained in the fluidized bed reactor is much superior in quality to the activated carbons produced by conventional processes. Based on the experimental observations the optimum values of process parameters are identified. The adsorption capacity of an adsorbent depends on its surface area, pore size, pore size distribution and pore volume. Satya Sai and Krishnaiah (2005) characterized the activated carbon produced in fluidized-bed reactor using coconut shells in terms of the pore size, pore size distribution, micro pore volume, external surface area and average pore size. The effects of various parameters, viz., reaction time, fluidizing velocity, particle size and temperature of activation, using steam and CO₂ as activating gases on the above mentioned characteristics of activated carbon were evaluated. The reaction time, temperature and fluidizing conditions showed significant effects on the pore-size distribution, pore volume and average pore diameter. Activating gases also had considerable effects on the characteristics of activated carbon produced in a fluidized bed reactor.

The various methods of production of activated carbon (physical activation using elevated temperature and super heated steam, chemical activation employing activating chemicals and high temperature, etc.) and its chemistry, effect of production conditions on properties and end- uses are reviewed by Dhamodaran and Gnanaharan (2008). In India, rotary kiln technology is the well established method for commercial scale production of activated carbon of any specification to suit all process applications. As down-scaled versions rotary kiln plants are not available due to its inherent techno-economic limitations, an alternative technology of fluidized bed reactor system is

looked by them and is found more appropriate for small or community scale production of granular shell active carbon. Medium grade coconut shell activated carbons produced by them through appropriated down-scaled technology employing a newly developed fluidized bed reactor (FBR) (Fig. 2) suitable for industrial production by community level organizations (CBOs) have found to have the prime use in drinking water purification due to its capability to produce granulated activated shell carbon with moisture content <5%, iodine value 450-900 mg/g conforming to Indian Standards 9BIS 1995). FBR developed was with an input capacity of 0.25 tone charcoal per day which can produce 0.125 tone of active carbon with a yield of around 50%.



(2. a)

Fig. 2. (a & b)
Side views of the
FBR Charcoal Activation Plant



(2. b)

7.7. Economics for Sustainability

Economics of community or cluster or small scale production of coconut shell charcoal alone showed that a plant with a minimum input capacity of above 3 tones will be profitable and will reach a payback period within 2.3 years. Utilizing the shell charcoal produced for activated carbon production is found extremely profitable (1200%) than directly selling the charcoal. Such an active carbon plant is found reaching its payback period within a year. Detailed project economics of establishing a 6 tone per day shell input capacity charcoal plant and utilizing the charcoal thus produced for activated carbon production by employing the newly developed FBR is has been convincingly found that small scale production of coconut shell charcoal and activated carbon at the community or cluster level is extremely profitable and worth promotion for improved livelihood of the poor and marginalized coconut farmers (Dhamodaran and Gnanaharan 2008).

8. MATERIALS AND METHODS

8.1. Charcoal Production Plant: Development of a Continuous Vertical Carbonizer

A continuous vertical carbonization pilot plant of 2 ton input capacity per shift of 8 hours (*i.e.*, 6 tonnes coconut shell input capacity per day) was designed fabricated (Fig. 3).



Fig. 3. Vertical carbonizer with coconut shell dryer

8.2. Description of the carbonizing plant with coconut shell dryer

The carbonizer designed is a continuous vertical type kiln lined with refractory bricks; the detailed engineering drawing is given in Fig. 4. The dimensions of sections are noted in the main drawing. A furnace is attached with the chimney for burning the volatile matter let out to the atmosphere through the chimney of 0.40 m diameter and 4.65 m height from the ground level. The carbonizer is an assemblage of three different chambers. The top portion of the plant is the dryer unit which dries the coconut shell. The top most component of the dryer unit is a conical shaped dryer feeder hopper (1) having a top and bottom diameter of 900 mm and 750 mm respectively, 600mm height and 4 mm thickness. Just below the feeder is a dryer shell (2) having top conical & bottom cylindrical portions. Conical portion is having a top diameter 750 mm, bottom diameter 1250 mm, 1250 mm height and the cylindrical portion is having 1250 mm diameter and 625 mm height. There is a flange connecting the dryer feeder hopper to dryer shell having internal diameter 750 mm and external diameter 850 mm and 12mm thickness. There are two leg supports for the dryer shell at the sides. The dryer shell is attached to an air distribution cone (3) with top diameter 1260 mm, bottom diameter 500mm and 1250 mm height. The door (4) of the dryer is attached to the distribution cone which can open up to 135° to feed the dried coconut shell to the carbonization reactor. The top most portion of the carbonisation reactor is feeding hopper (5) into which the door of the dryer unit opens to feed the coconut shell. The feeding hopper is connected to the main portion of the

Carbonization Reactor (6), which is cylindrical in shape at the top, (1500 mm internal diameter, 1250 mm height); the bottom portion is conical in shape having 1800 mm height and 1500 mm internal diameter at top to 1100 mm at bottom. There is a flange connecting the feeding hopper & carbonization reactor having internal diameter 1500 mm, external diameter 1650 mm and 12 mm thickness. There is a char receiver cone (7) just below the carbonization reactor with 810 mm height; with internal diameters of 1300 mm at the top and 800 mm at the bottom. Through the char receiver cone, the char reaches the pusher assembly (8) from the carbonization reactor. The pusher assembly pushes the char into the collection assembly (9) through the connector (10) which provides an airtight storage. The collection cans are moved out using a trolley mechanism (11). There is a furnace connection pipe (12) connected to the top portion of the carbonizer to take out the volatile substances to the furnace. The furnace connection pipe carries the volatile substances through a connection pipe (13) to reach the waste heat recovery boiler (14) situated just below the furnace. The recovery boiler uses the energy to dry the shells in the dryer unit. There is a connection pipe (15) and connection bend assembly having 300 mm diameter (16) which carries dry air to the dryer outlet from the recovery boiler. The coconut shells are carried to the top of the dryer feeder using a vertical movement arrangement (17) with rollers having 125 mm square cross section and 11000 mm height. There is a shell carrier (18) mounted to the rollers of the vertical movement arrangement (hoist) which carries and supplies shells to the drier. The shell carrier is square at the top with 700 mm cross section and conical at bottom with a 400 mm door.

All the chambers are made out of 6mm MS sheets externally lined with cold refractory bricks and internally lined with hot refractory bricks, both of 150 mm thickness. The gaps between the linings are filled with castable clay (special type of cement used in refractory work). The top conical shaped cover of the plant is also made with SS. Thermometer wells and viewing glass frames, pushing bars and shafts are also made with SS. All other supporting materials and accessories like chimney, lift, dryer shell unit etc. are made with MS/GI sheets/pipes.

To lift the raw material from the ground to the hopper a lift mechanism with 1 HP motor is provided (17). For withdrawal of product, an outlet pipe is fitted at the bottom portion of the plant; a gear and belt drive shaft and rotating arm mechanism with 1 hp motor (8) is provided to push out the charcoal produced.

The volatile substances from the carbonizer is taken through a pipeline insulated with refractory bricks, to a furnace (14) where it get burnt and let away to the atmosphere through a chimney. Heat recovery option is provided in the furnace for taking the waste heat, if required. Inside the carbonization plant (6), the material is burned with limited access to air, controlled by equidistantly placed air vents; 14 numbers in the middle chamber (provided as two rows; distance between the rows is around 0.8 m) and 4 in the bottom chamber (as single row). Digital thermometers (pyrometer type with range 0-1500^o C; one in each in each chamber) are provided to record the working temperature of the plant.

For charcoal collection from the outlet pipe, withdrawal cans having water seal in its mouth portion to prevent entry of air through the product pipe and thereby to the plant are provided (9).

A pulverizer with 2 HP motor is used to crush the charcoal to desired sizes for activation. Sieves of appropriate meshes are used for sieving the crushed charcoal. Sieving is done manually.

8.3. Engineering Drawing of Continuous Vertical Carbonizing Charcoal Plant

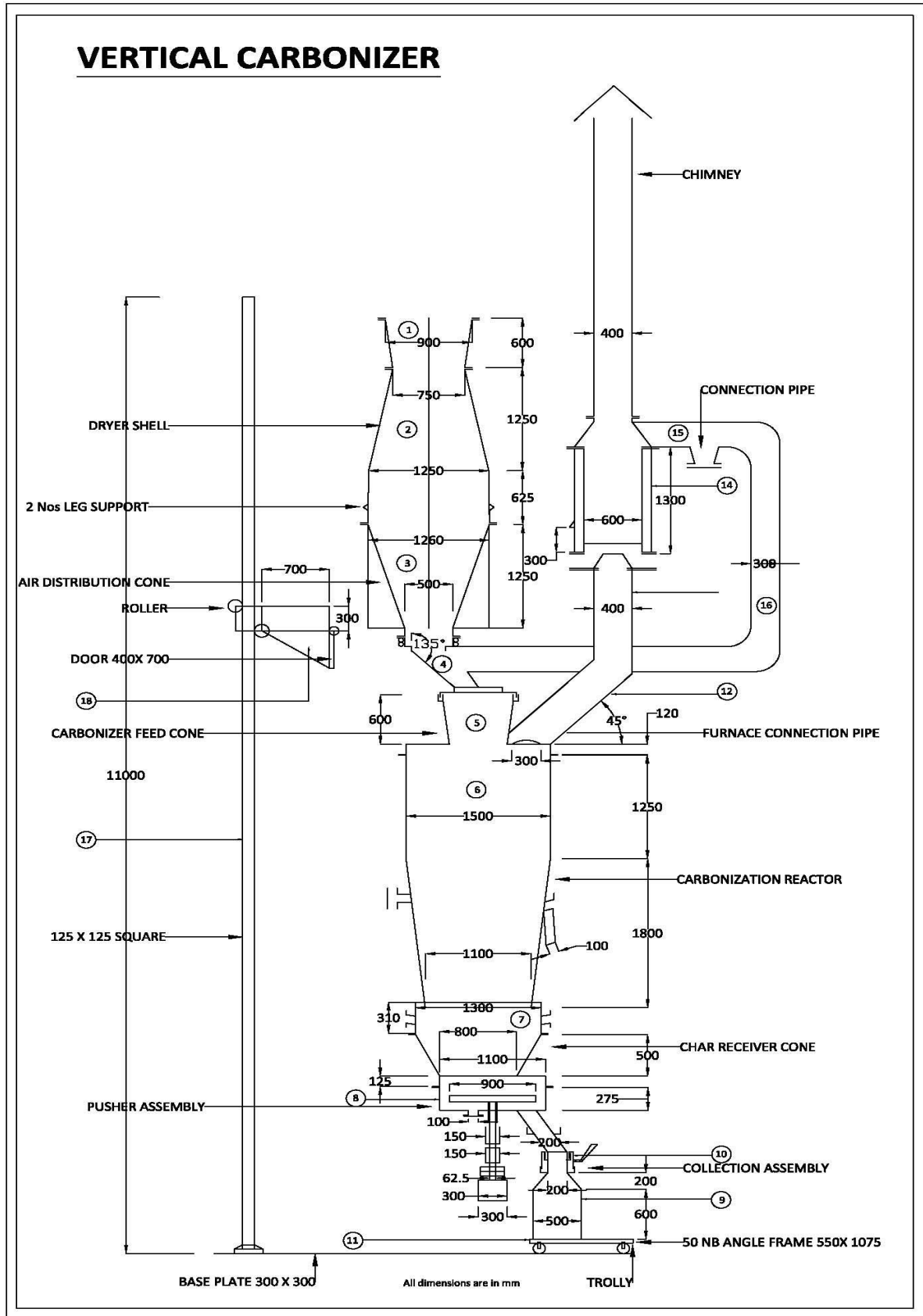
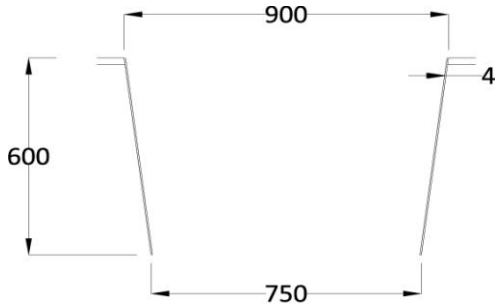

Fig. 4. Engineering drawing of the Vertical carbonizer with coconut shell dryer

8.4. Detailed Engineering Drawings of the Main Components of the Carbonizing Plant

DRYER FEED HOPPER 4 MM



DRYER SHELL

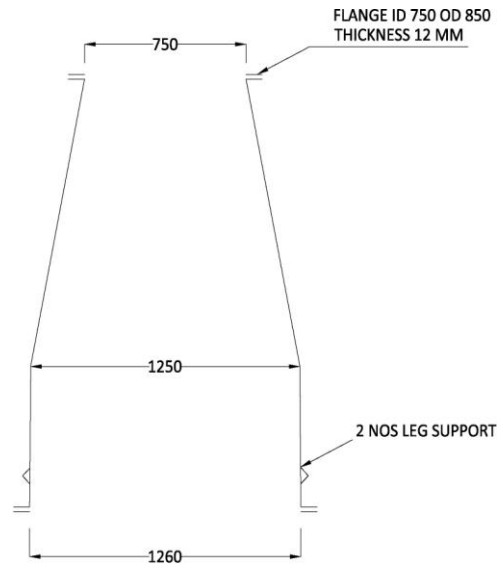

AIR DISTRIBUTION CONE

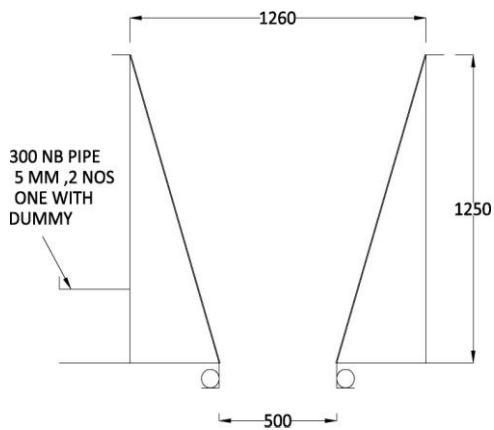

FRONT DOOR 500 MM TO BE OPEN

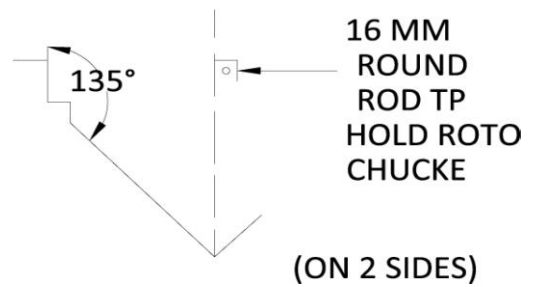

CARBONIZER FEED CONE

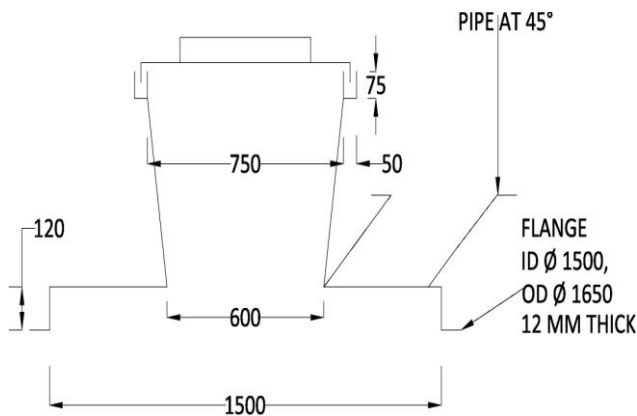

CHAR RECEIVER CONE

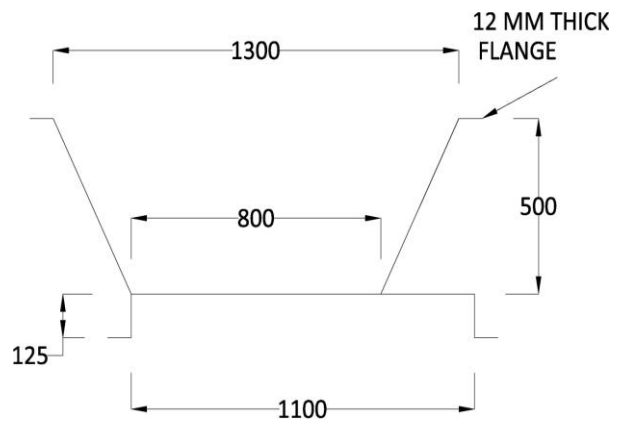

CARBONIZATION REACTOR

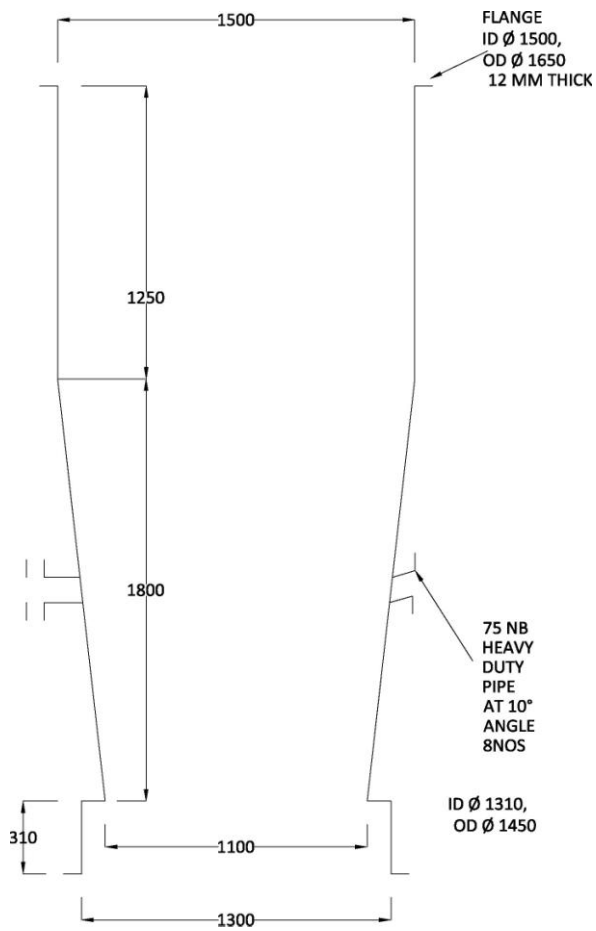

PUSHER ASSEMBLY

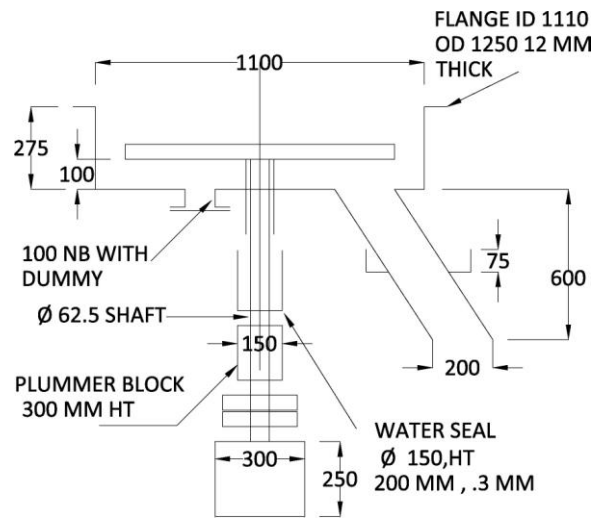

CONNECTOR

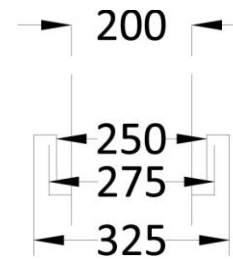

COLLECTION ASSEMBLY

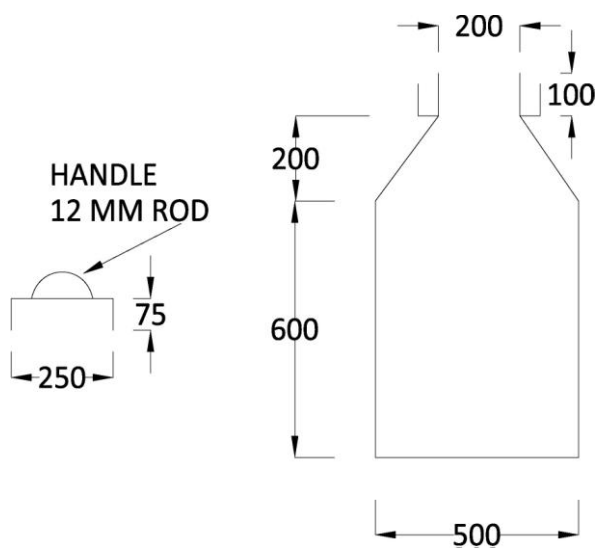

TROLLEY

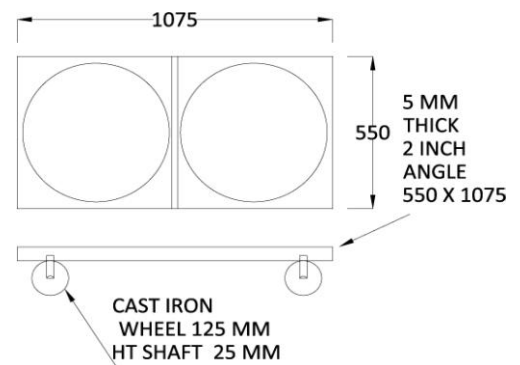

FURNACE CONNECTION PIPE

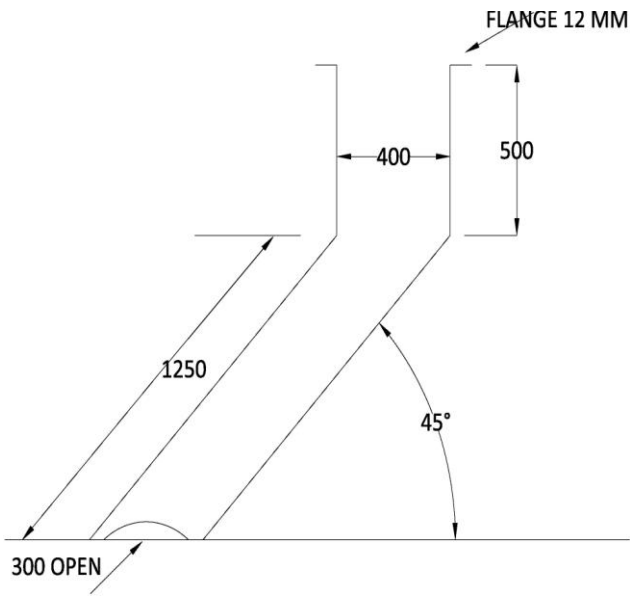

CONNECTION PIPE TO BOILER

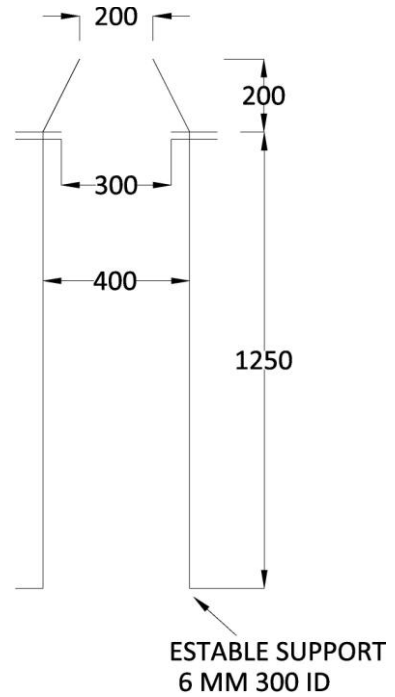

WASTE HEAT RECOVERY BOILER

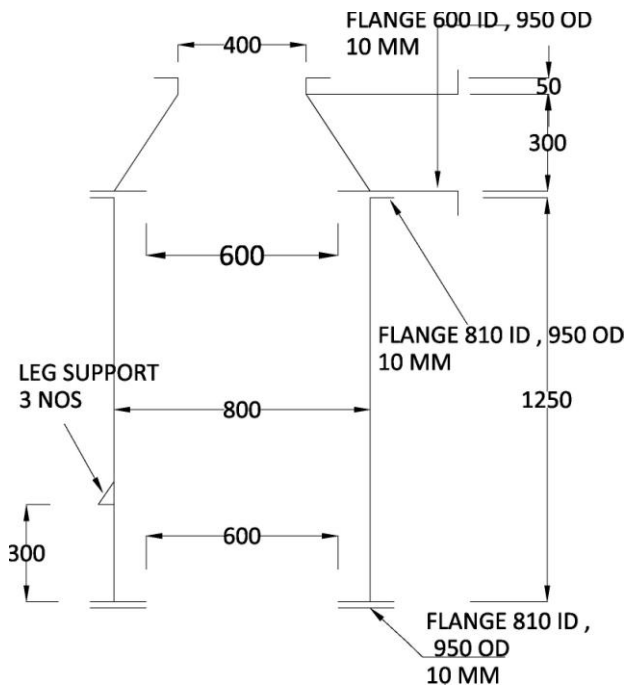

CONNECTION PIPE

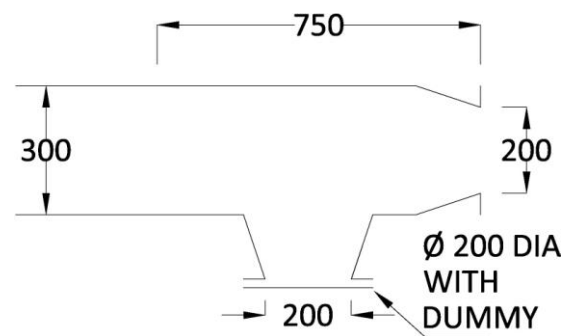

VERTICAL MOVEMENT ARRANGEMENT

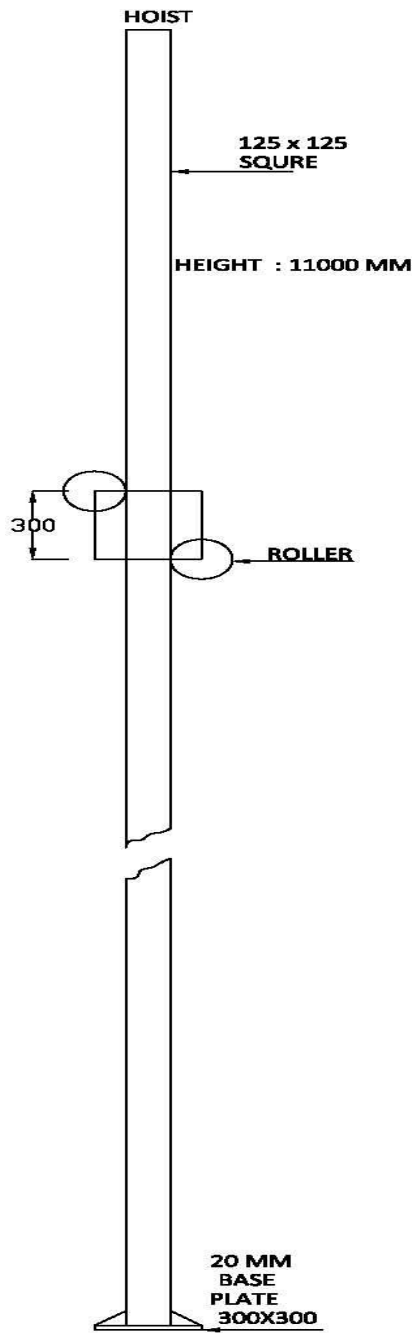

CONNECTION BEND

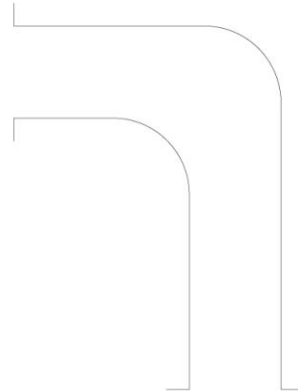

SHELL CARRIER

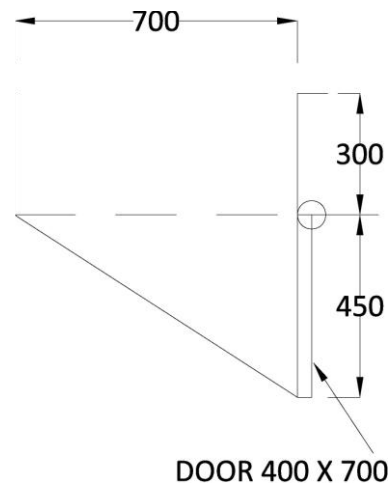

ROLLER MECHANISM

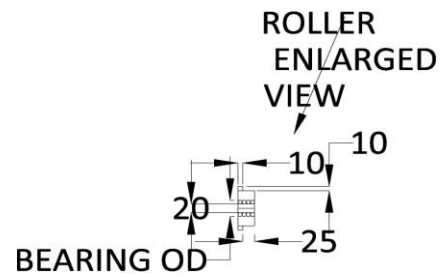

8.5. Layout of the Carbonizing Plant

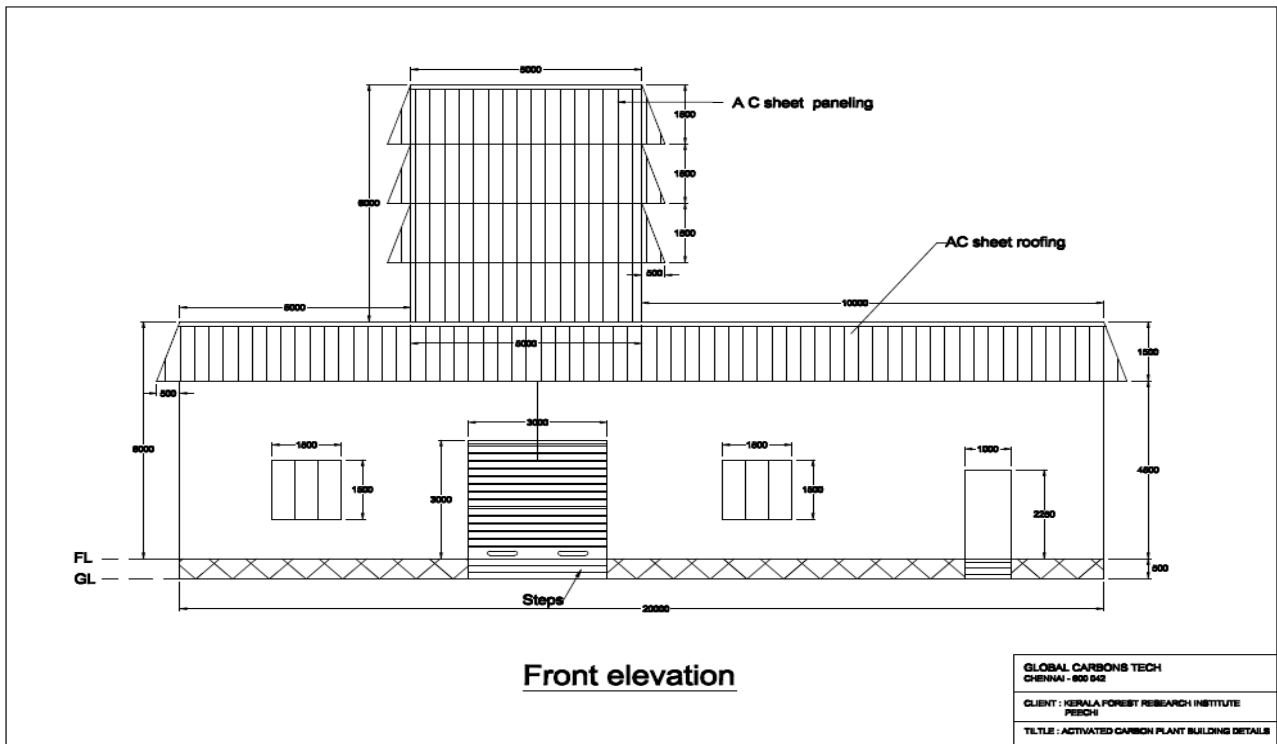

Fig. 5.1. Front Elevation of Carbonizing Plant

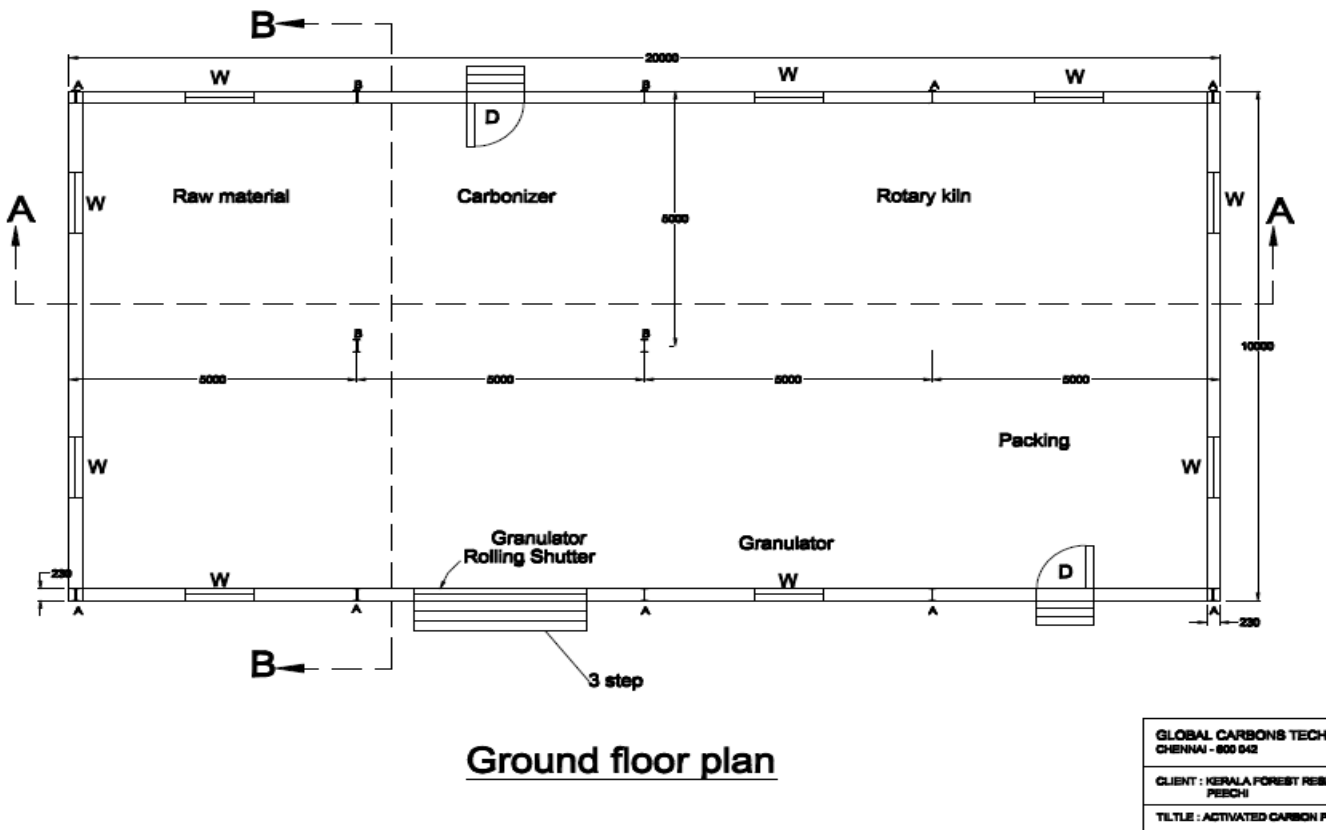

Fig. 5.2. Ground Floor Plan of Carbonizing Plant

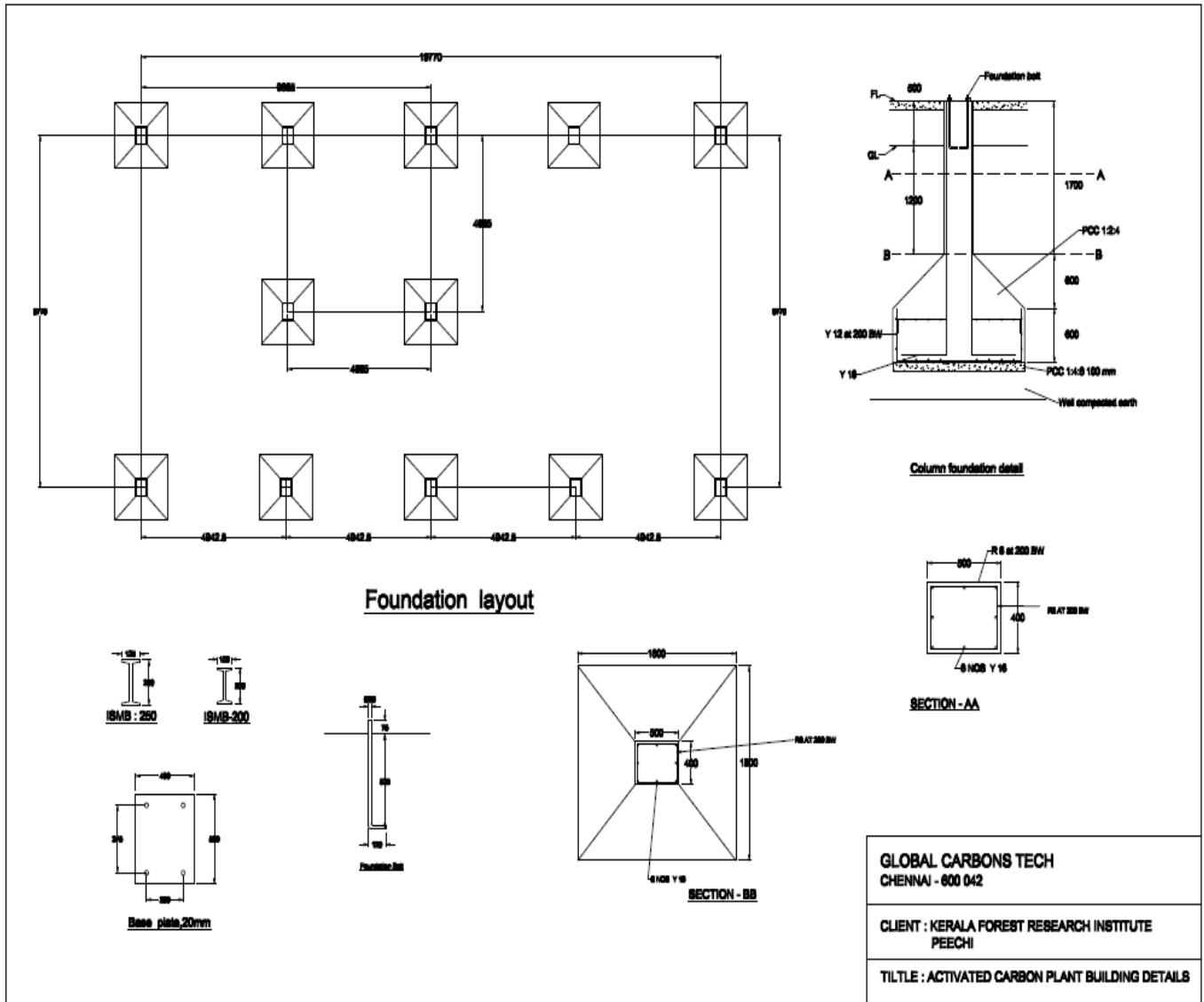

Fig. 5.3. Foundation layout of Carbonizing Plant

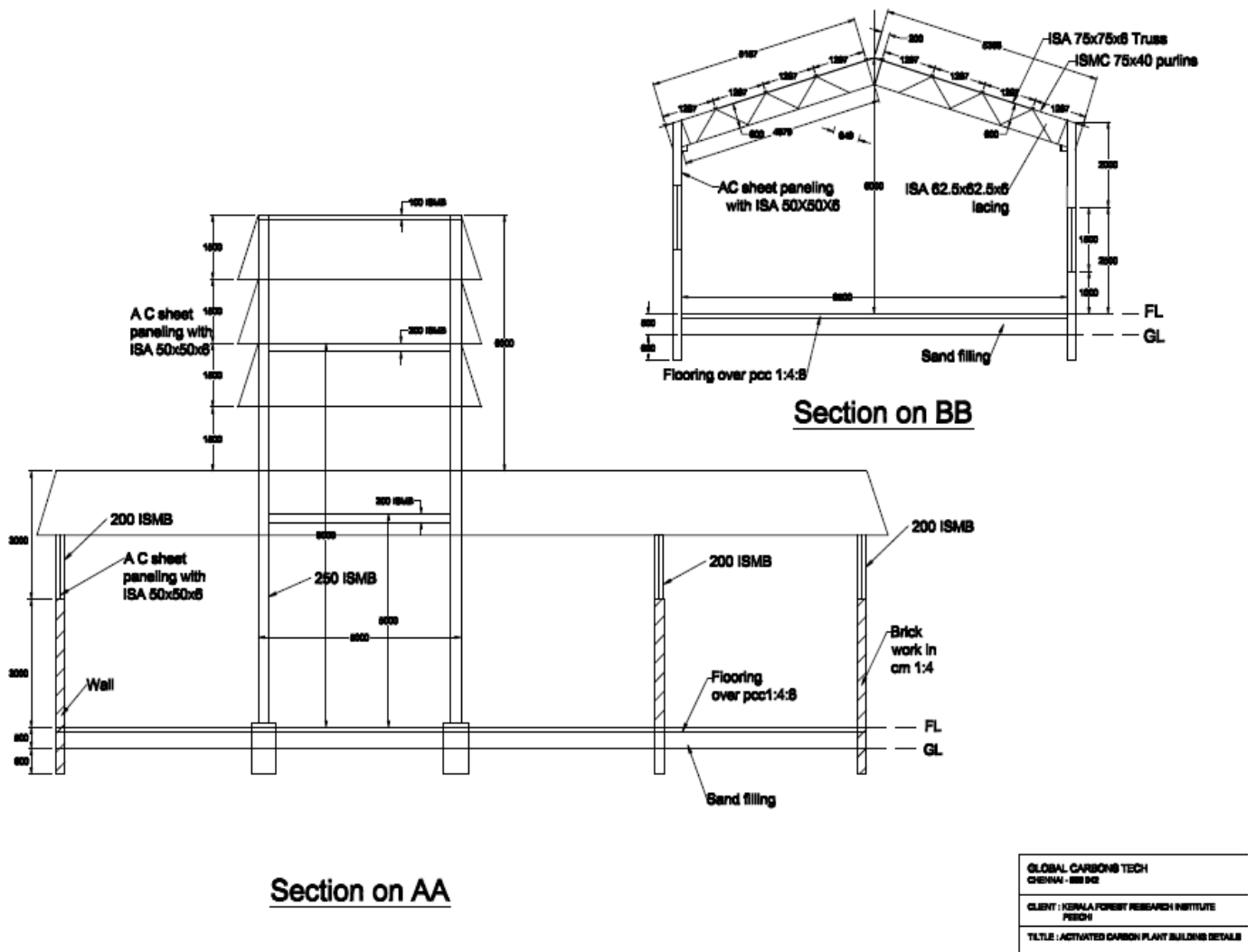

Fig. 5.4. Sectional Elevation of Carbonizing Plant



Fig. 5.5. The work site - Foundation

8.6. Activated Carbon Production Plant - Development of a Rotary Fluidized Bed Reactor

Technical upgradation of the design of an earlier fluidized bed reactor (FBR) system developed by Dhamodaran and Gnanaharan (2008) (with the advantages of cost effectiveness, excellent gas - solid contact, and high heat and mass transfer rates) was planned so as to incorporate the technical benefits of rotary kilns (higher activation temperature, better movement of the material due to the external physical rotation provided, etc). Accordingly, a Rotary Fluidized Bed Reactor (RFBR) system was conceptualized, designed, fabricated and installed in the campus of the Central Plantation Crops Research Institute (CPCRI) of the Indian Council of Agricultural Research (ICAR) at Kasaragod, Kerala. A photograph of the RFBR Activation Plant developed is given in Fig. 6.



Fig. 6. Newly developed RFBR Shell Charcoal Activation Plant

8.7. Engineering Design Drawing of the Rotary Fluidized Bed Reactor (RFBR) Activation Plant Developed

Rotary Fluidized Bed Reactor

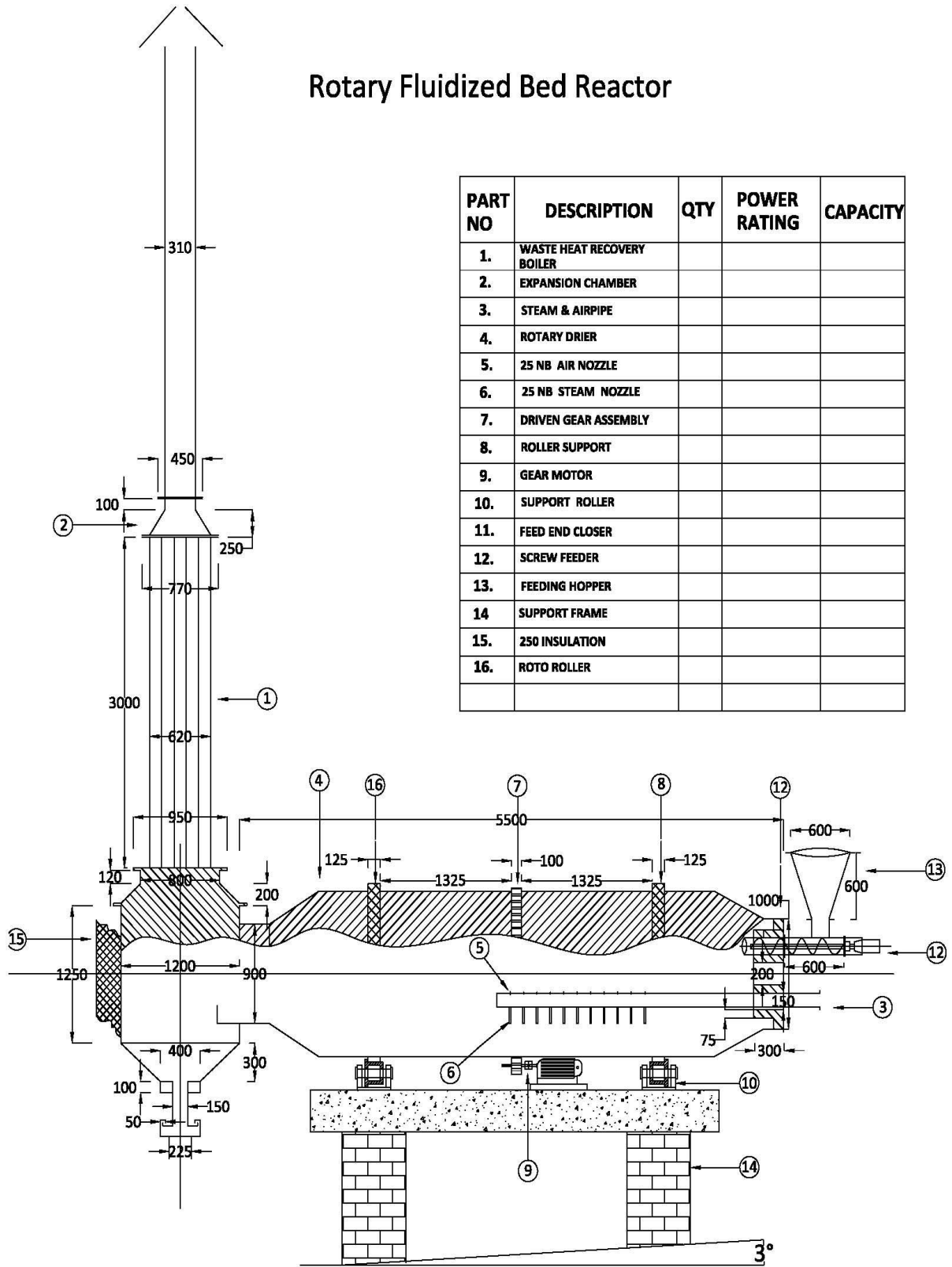

PART NO	DESCRIPTION	QTY	POWER RATING	CAPACITY
1.	WASTE HEAT RECOVERY BOILER			
2.	EXPANSION CHAMBER			
3.	STEAM & AIRPIPE			
4.	ROTARY DRIER			
5.	25 NB AIR NOZZLE			
6.	25 NB STEAM NOZZLE			
7.	DRIVEN GEAR ASSEMBLY			
8.	ROLLER SUPPORT			
9.	GEAR MOTOR			
10.	SUPPORT ROLLER			
11.	FEED END CLOSER			
12.	SCREW FEEDER			
13.	FEEDING HOPPER			
14.	SUPPORT FRAME			
15.	250 INSULATION			
16.	ROTO ROLLER			

8.8. Description of the RFBR

The Rotary fluidized bed reactor (RFBR) is a refractory-brick lined furnace. It is cylindrical in shape and positioned horizontally (rotary drier) (4) (*reference to Fig. 8.7*) made up of 6 mm MS sheets. The Rotary drier is with dimensions of 5.5 m length and 1.5 m diameter. The rotary drier has two ends, right end connected to expansion chamber (2) and left end connected to screw feeder and end closer (12). Here, the feeding hopper (13) is operated by screw feeding mechanism. A screw feeding mechanism with 1 HP motor is provided for feeding the raw materials (charcoal) into the rotary drier. One end of screw feeder is connected to 1 HP motor shaft and other end is connected to the feed-end closer (12). The rotary drier is placed over support frame (constructed with brick) in a length and height of 5.5 m and 0.8 m respectively (14). Two pair of supporting rollers (8) and a single gear assembly with motor (3HP) (7) is placed between the rotary drier and support frame. The support frame and its rollers (10) carry all loads of rotary drier plus raw materials, and make the smooth rotation of rotary drier (4). One gear driven motor at the centre (9) and two roto-rollers (16) at the fringes of rotary drier is provided for smooth rotation of klin. A 3 HP motor is provided at the bottom portion of the rotary drier to connect gear assembly through the motor shaft. The pipe measured 50 mm diameter with 3 m length (3) is fixed in to the rotary drier through feed end closer (11). The pipe has two kinds of nozzles; one for transmitting air and another for steam (5 & 6), each nozzle measured 12.5 mm diameter. Right end of the rotary drier has combustion chamber with dimensions of 1.2 m diameter and 1.25 m height. The combustion chamber is insulated with refractory bricks of 250 mm thickness (15). Waste heat recovery boiler (1) is fixed at the top of combustion chamber with a dimension of 3 m height and 6 m diameter to produce sufficient steam, which is required during the process of activation. One water inlet nozzle, steam detection nozzle and steam outlet nozzle are provided in the waste heat recovery boiler. The water inlet nozzle is directly connected to controllable water pipe and steam outlet nozzle is connected to the air and steam nozzle in the left end of the rotary drier. Above the boiler, a chimney is provided to allow the burnt gases to escape to the atmosphere. A rotary valve mechanism with 1 HP motor was provided at the bottom of combustion chamber to withdraw the product, activated carbon, through the outlet pipe.

An air compressor (3 HP) is used to blow air into the system through the air nozzle (5). The volatile in the rotary drier is burned in an attached combustion chamber and the waste heat recovered is used for the boiler for the production of super heated steam by using a super heater. Superheated steam is admitted through air steam-nozzle to rotary drier. A 0.5 HP motor is provided to pump water to the tank. The water tank is connected to the boiler. In case of a failure in keeping the desired water level in the boiler, a non-returnable valve (NRV) fitted between the water tank and boiler prevents the return of steam from boiler to the pipeline and water tank and thereby safeguarding the collapse of pipeline, tank and the boiler itself. The NRV necessitates another motor (0.5 HP) to pump water from the tank to the boiler. Thermometer wells, pushing bars, shafts and viewing glass frames are made with SS. Air flow pipes and other pipes inside the activated carbon plant are made with SS. All other supporting materials and accessories like chimney, lift, etc., are made with MS/GI sheets/pipes.

8.9. Detailed Engineering Drawings of the Main Components of the RFBR Activation Plant

Waste Heat Recovery Boiler

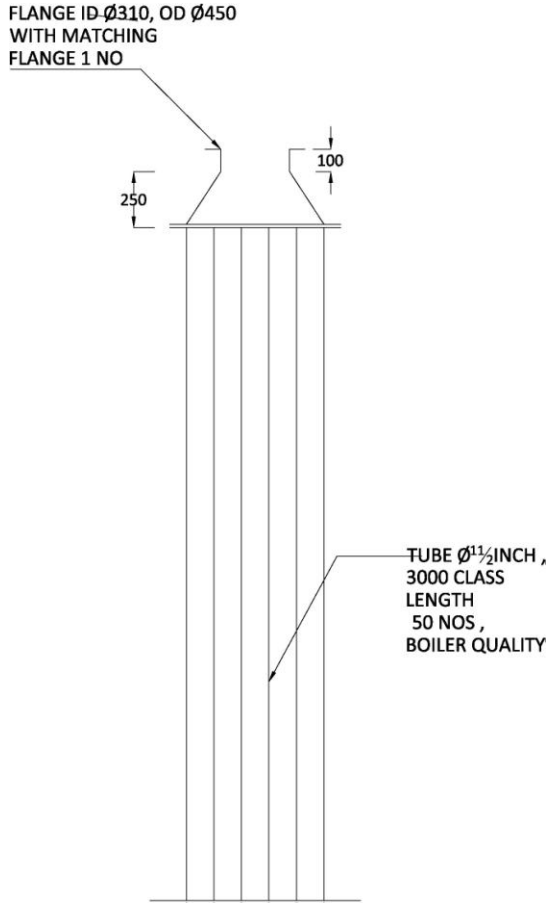

Combustion/Expansion Chamber

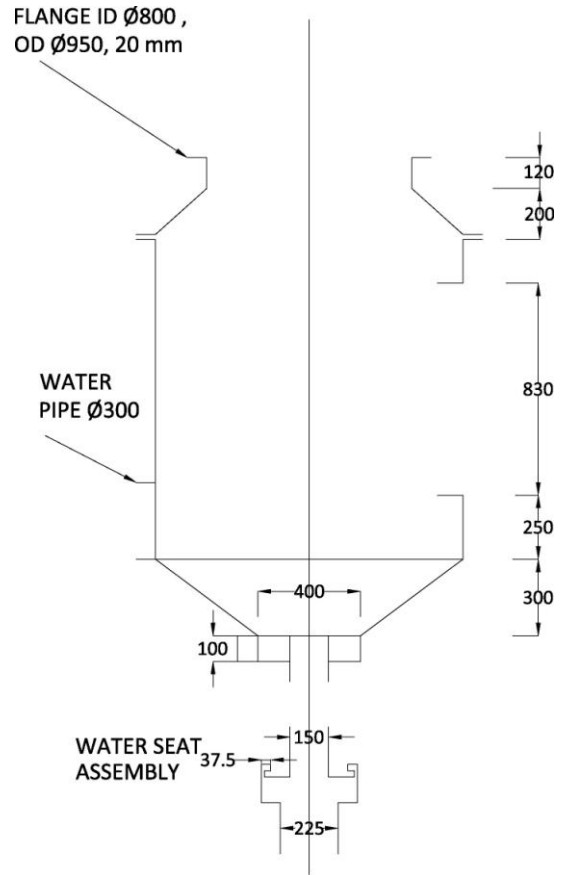

Steam Pipe & Air Pipe with air & steam nozzles

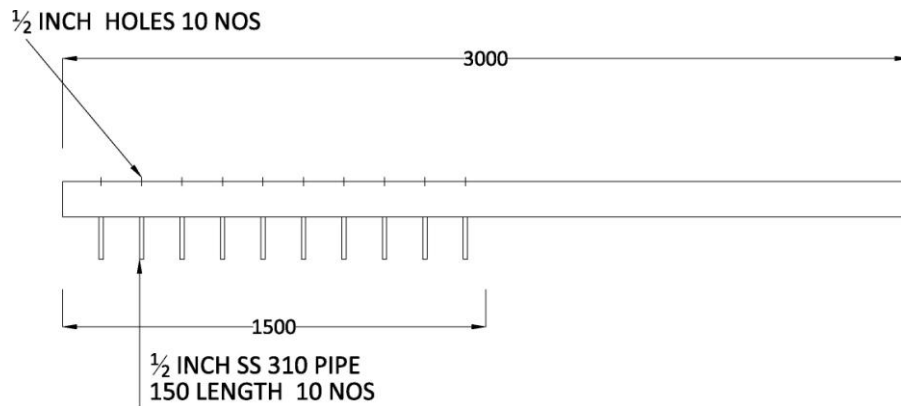

Rotary Dryer

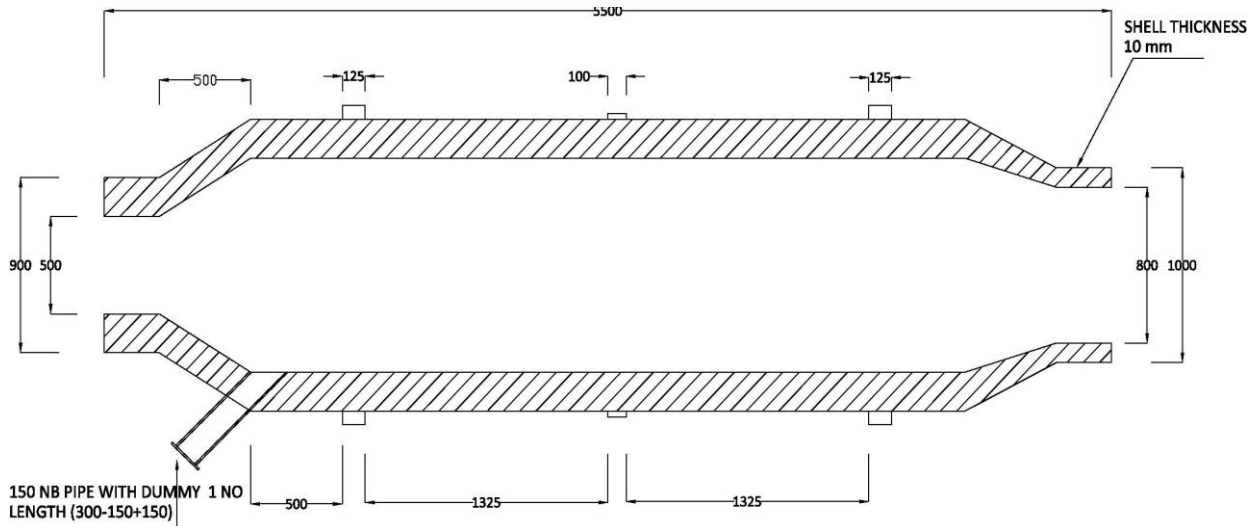

Drive Gear

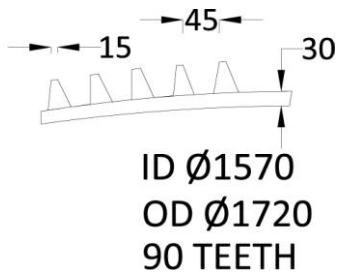

Roller Support

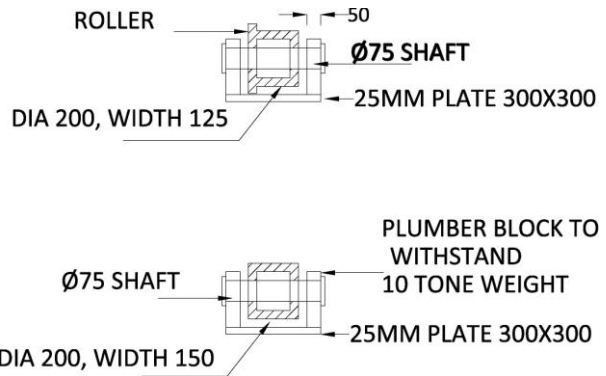

Roto-Roller

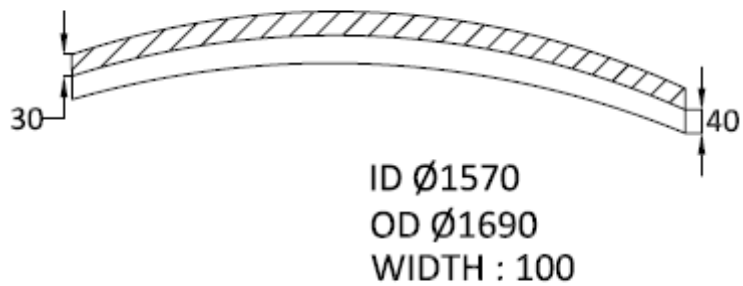

Feed End Closer

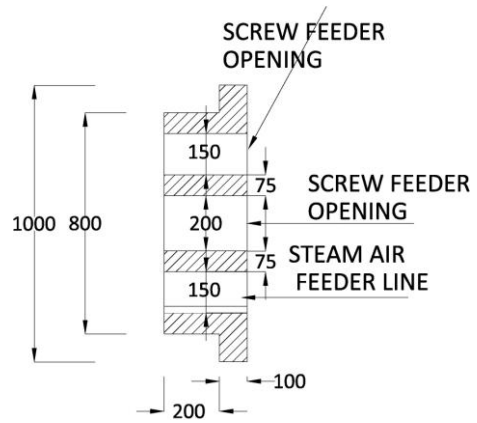

Screw Feeder

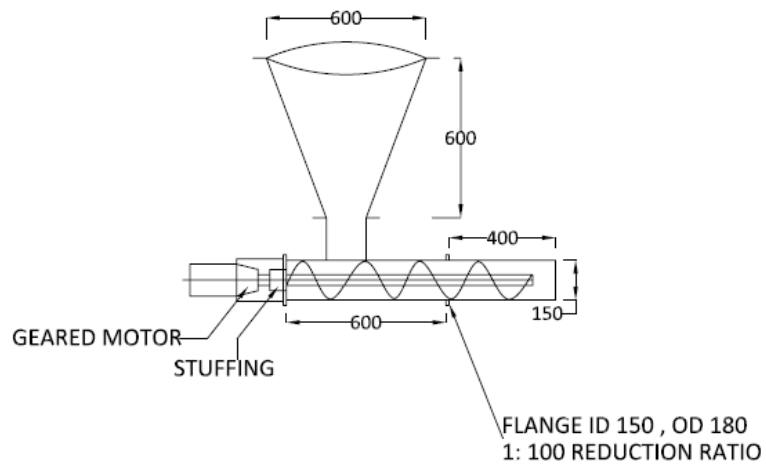

Feeding Hopper

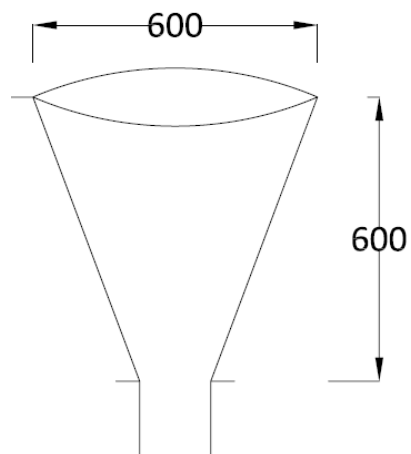

8.10. Main Components of the RFBR Activation Plant

Internal view of RFBR (before fire brick lining)



Internal view of RRBR (after brick lining)



Screw feeder



Steam nozzils



Gear and rotating system in RFBR



Rotating system in RFBR



Complete view of pulveriser



Inside view (blades) of pulveriser



Supporting joints and rotating gears



Fire bricks



8.11. Work Shed & Plants

Front view of the constructing plant



Full view of the RFBR



Side view of the plants and shed



Inside-view of the completed plant



8.12. Assessment of Yield and Quality of Products

Yield of charcoal and activated carbon are determined on oven dry (OD) basis by weighing the raw material and products after correcting for moisture content (MC, %) at test condition. Moisture content was determined by oven dry method.

Quality parameters of charcoal and activated carbon were determined as per standard procedures. Quality parameters such as moisture content, volatile content, ash content, fixed carbon content, iodine value, etc., were determined by chemical analysis (BIS 1984, 1989, 1992, 1995, 2002, ASTM 1977).

The method essentially consists of oven drying (at 105 °C) pre-weighed air dried (AD) charcoal dust that pass through 850 micron IS sieve and recording the oven dry weight of the sample, from which moisture content is calculated. Volatile content was determined on the oven dried sample by using a muffle furnace at a temperature of 300-500 °C and weighing the cooled sample. Ash content is determined on the same sample used for volatile content determination by igniting the sample in a muffle furnace at 750 °C for 6 hours and weighing the cooled ash. Fixed carbon content was calculated by subtracting the sum of volatile content and ash content of the OD sample from 100.

Iodine number test being easier to run than the BET (m²/g) test, it is commonly used in industries as a quality indicator of the active carbon product. Iodine value was determined on 0.2g finely powdered samples that pass through a 75 micron IS sieve. Introduce the carbon powder into an iodine flask; add 40 ml of 0.1 N iodine solution. Shake the contents for exactly 4 minutes. Filter through a Whatman No. 1 filter paper. Take 10 ml of the filtrate and titrate against standard (0.05 N) sodium thiosulphate solution (use exactly 0.1 N potassium iodate solution for the standardization of sodium thiosulphate solution using starch indicator; standardize the iodine solution against the standardized sodium thiosulphate solution using starch indicator; and calculate the quantity of iodine adsorbed from the quantity of iodine mg/g in the original solution and the quantity of iodine in the filtrate by taking difference). Iodine value of commercial laboratory grade active carbon from BDH is also determined for comparison purpose.

8.12.1. Methods of Charcoal Quality Analysis

ASTM method (ASTM D 1762-64 (re-approved 1977) was followed for the determination of moisture content, volatile content, ash content and the fixed carbon content of charcoal samples (ASTM 1977). Iodine value, the most appropriate indicator of the adsorptive capacity, was determined by the Indian Standard IS 2752: 1995 (BIS 1995).

The flake or granular shell charcoal is ground to pass a No. 20 (850 micron) sieve and retained on No. 100 (150 micron) is selected and the tests were carried out on 1 gm samples. The essentials of the procedure of chemical analysis are as detailed below:

8.12.1.1. Determination of Moisture Content:

Moisture content was determined by oven drying method. From the weight difference, moisture content is determined on an oven dry (OD) basis.

$$\text{Moisture content (\%)} = [(\text{Initial weight} - \text{OD weight})/\text{OD weight}] \times 100$$

8.12.1.2. Determination of Volatile Content:

Heat a muffle furnace to 950⁰ C. Preheat the silica crucibles used for the moisture determination, with lids in place and containing the oven dried (moisture free) samples, as follows: with the furnace door open, for 2 minutes on the outer edge of the furnace (300⁰ C) and then for 3 minutes on the edge of the furnace (500⁰ C). Then move the samples to the rear of the furnace for 6 minutes with the muffle door closed. Watch the samples through the small peep-hole in the muffle door. Cool the samples in a desiccator for 1 hour and weigh.

$$\text{Volatile content (\%)} = [\text{Weight loss due to volatiles}/\text{Original weight of moisture free sample}] \times 100$$

8.12.1.3. Determination of Ash Content:

Place the lids and the uncovered crucible used for the volatile matter determination containing the sample (both moisture and volatile free) in the muffle furnace at 750⁰ C for 6 hours. Cool the crucibles with lids in place in a desiccator for 1 hour and weigh. Repeat burning of the samples until a succeeding 1 hour period of heating results in a loss of less than 0.0005 gm.

$$\text{Ash content (\%)} = [\text{Weight loss}/\text{Original weight of moisture and volatile free material}] \times 100$$

8.12.1.4. Determination of Fixed carbon content:

$$\text{Fixed carbon content (\%), on OD basis} = [100 - (\text{per cent volatile content} + \text{per cent ash content})]$$

8.12.1.5. Determination of Iodine value

Iodine value was determined on 0.2 g finally powdered samples that pass through a 75 micron IS sieve. Introduce the charcoal powder into an iodine flask; add 40 ml of 0.1 N iodine solution. Shake the contents for exactly 4 minutes. Filter through a Whatman No. 1 filter paper. Take 10 ml of the filtrate and titrate against standard (0.05 N) sodium thiosulphate solution (use exactly 0.1 N potassium iodate solution for the standardization of sodium thiosulphate solution using starch indicator; standardize the iodine solution against the standardized sodium thiosulphate solution using starch indicator; and calculate the quantity of iodine adsorbed from the quantity of iodine mg/g in the original solution and the quantity of iodine in the filtrate by taking difference).

8.12.2. Methods of Analysis of Activated Carbon

8.12.2.1. Materials:

Samples of activated granular carbon from coconut shell charcoal produced by KFRI by employing the newly developed rotary fluidized bed reactor (RFBR) pilot plant were used as the material for the present study.

8.12.2.2. Methods:

Indian Standard method, IS 877: 1989, was followed for the determination of moisture and ash content of active carbon samples (BIS 1989). Iodine value, the most appropriate indicator of the adsorptive capacity, was determined by the Indian Standard IS 2752: 1995 (BIS 1995).

8.12.2.2.1. Determination of Moisture Content

Moisture content was determined by oven drying method. From the weight difference, moisture content is determined on an oven dry (OD) basis.

Moisture content (%) = [(Initial weight - OD weight)/OD weight] x 100

8.12.2.2.2. Determination of Ash Content

Ash content was determined by igniting the sample in a muffle furnace at 1000⁰ C. From the weight difference ash content was calculated.

Ash content (%) = [10000 x Weight loss in g/{Original weight of material x (100 - Moisture content %)}]

8.12.2.2.3. Determination of Iodine Value

Iodine value was determined on 0.2 g finally powdered samples that pass through a 75 micron IS sieve. Introduce the charcoal powder (0.2 g) into an iodine flask; add 40 ml of 0.1 N iodine solution. Shake the contents for exactly 4 minutes. Filter through a Whatman No. 1 filter paper. Take 10 ml of the filtrate and titrate against standard (0.05 N) sodium thiosulphate solution (use exactly 0.1 N potassium iodate solution for the standardization of sodium thiosulphate solution using starch indicator; standardize the iodine solution against the standardized sodium thiosulphate solution using starch indicator; and calculate the quantity of iodine adsorbed from the quantity of iodine mg/g in the original solution and the quantity of iodine in the filtrate by taking difference).

8.12.2.2.4. Determination of Surface Area

Nitrogen adsorption-desorption measurements were done on a volumetric Micrometrics Tristar apparatus at Liquid N₂ temperature, 77.35 K. On an average 33 points were taken for each sample. The average mass of the sample was 0.10 g. Pore size distributions were calculated using BJH method and surface areas were taken from BET isotherms.

9. RESULTS AND DISCUSSION

9.1. Operation of the Charcoal Plant

The holding capacity of the carbonizing plant is about 350 kg coconut shells. Introduce about 35 kg of coconut shells into the plant for ignition. As excessive air is not good for the partial combustion, all the air vents has to be closed tightly while igniting (the top of the plant, i.e., the hopper portion is always opened). Usually the ignition is started either with kerosene or diesel. Around 1 litre of kerosene and a meter of waste cotton are required for igniting the shells in the plant. A piece of cotton waste dipped in kerosene is fired externally and dropped into the plant through the hopper. The coconut shells may take 20 to 30 minutes to get ignited and this will lead to the formation of a stable fire bed of coconut shells. After such a stabilized burning fire bed formation, rest of the load in batches of about 70kg is added to the plant. While adding more and more shells, sometimes fire may get off due to insufficient air supply; then immediately open all the air vents in the middle storey and fire externally by inserting a piece of burning kerosene soaked cotton through selected air vents of both the rows of the middle storey.

After the fire bed formation, add coconut shells continuously with careful monitoring of the temperature readings in all the zones of the carbonizer so as to avoid excessive burning since it is important for restoring adequate volatile material in the charcoal. Maintain the temperature readings below 400⁰ C in the middle zone where the combustion process occurs. When the temperature increases, immediately withdraw some charcoal until the temperature gets reduced. It takes about an hour after filling the first charge for the first time collection of charcoal. Care should be taken while withdrawing charcoal, as withdrawing more quantity of charcoal in a single attempt will lead to excessive loss of temperature in the middle and top zones of the plant. Being a continuous process, regular time gap should be maintained for every product withdrawal in such a way to prevent heat loss and maintain the optimal temperature. A withdrawal schedule of 1 to 3 minutes charcoal collection within a regular time interval of 10-20 minutes depending upon the temperature readings is suggested.

Once the temperature is stabilized to the desired level, air vents should not be closed too tightly; vents should be kept in such a way so as to facilitate easy opening when temperature falls down. Within two hours, a fire can be lightened up in the furnace attached to the chimney to burn the volatile substances completely before reaching the atmosphere.

Place the water sealed product withdrawal can below the output pipe for collecting the charcoal. Once withdrawal can is filled up with charcoal, remove it from the output pipe and close it with its lid for few minutes to avoid any further open burning by direct exposure to air. The withdrawn charcoal should be spread over the dried floor for cooling. The hot charcoal has to be checked thoroughly for any fire or sparks remaining. If any fire/spark is found, quench it with a water spray; otherwise it will get fully burnt to ash. The cooled charcoal may be packed in sacks and weighed for determining the yield.

One person is required to with draw the charcoal and one for loading the input materials on the lift. It is always recommended to run the carbonizer continuously forming three shifts per day.

Adequate stock of the raw material (shells) should be ensured. Completely dried raw materials should be used in order to avoid heavy smoke problem at the initial stage of process which in turn can affect the yield too. Raw materials should be placed near the lift and a weighing balance

(platform balance) adjacent to the lift. All the input shell loadings and output charcoal should be weighed for quantifying the yield.

Care should be given to the working condition of the plant. It should be ensured before igniting the plant that all motors and lift is in working condition, as once the charge get ignited the process can't be stopped.

The charcoal needs to be pulverized into desired size. The raw material for activation should be pulverized charcoal of size that can pass through IS sieve 4 and retained in IS sieve 8. Charcoal should be loaded into the pulveriser/crusher (Figs. 17 & 18) immediately after switching it on; loading before switching on can lead to getting struck with the crushing blades. Close all the openings in the crusher box to avoid dust spreading. IS sieves 4 and 8 may be used for sieving the pulverized or crushed charcoal. On health point of view, it is suggested to wear nose strips to prevent inhalation of carbon dust produced while crushing and sieving the charcoal.

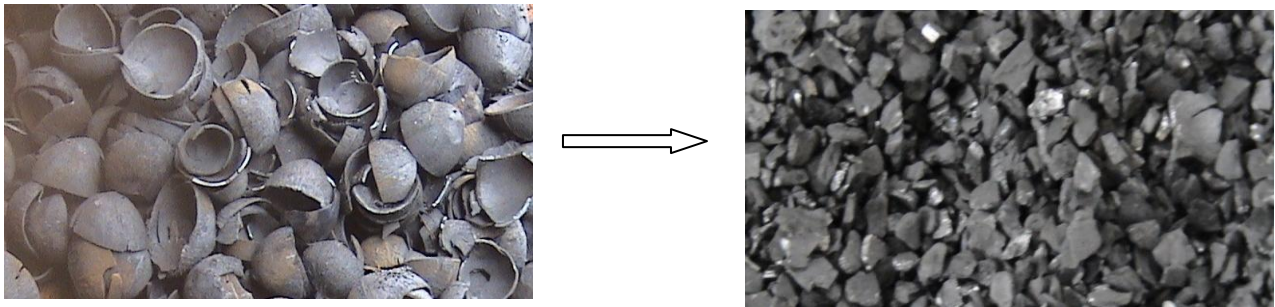

Coconut shell charcoal before and after crushing

9.2. Charcoal Quality

An average yield of 31.3 per cent (on OD, weight/weight basis) was obtained. The results of physical chemical analysis for ascertaining the quality of charcoal produced are given in Table 1.

The input output details recorded while conducting trial runs showed that after firing the charge, carbonization is stabilized within the first two hours and collection of charcoal can be started at this point. As far as quality of charcoal is concerned, carbonization at a higher temperature range of 500-800⁰ C yielded charcoal with significantly lower volatile content (8.8%). As charcoal with lower volatile content is preferred for industrial use, the newly developed carbonization plant is a success in this regard.

Ash content, another quality parameter of charcoal, is found to be 1-2 per cent (Table 1). Charcoal produced at higher temperature was found to have 905 fixed carbon; charcoal with higher volatile content will have proportionately lower fixed carbon. Thus the product, charcoal from the newly installed continuous vertical carbonization charcoal plant, is found conforming to the qualities specified in IS 13522 (BIS 1992) for industrial use.

Table 1. Quality of coconut shell charcoal produced from the newly installed charcoal plant at higher temperature range (500-800⁰ C; n=7)

Sl. No.	Mean Moisture Content (%)	Mean Volatile Content (OD basis, %)	Mean Ash Content (OD basis, %)	Mean Fixed Carbon Content (OD basis, %)
1	5.4	10.9	1.1	88.0
2	5.3	10.5	1.5	88.0
3	5.5	10.4	2.1	87.5
4	6.8	9.6	2.0	88.4
5	5.4	8.0	2.1	89.9
6	6.0	6.7	2.1	91.2
7	4.7	5.7	1.4	92.9
Mean	5.6	8.8	1.8	89.4
CV (%)	11.8	23.3	23.1	2.2
Range	4.7-6.8	5.7-10.9	1.1-2.1	87.5-92.9

Charcoal with higher volatile content desired for the economical production of activated carbon and for other uses could also be produced by lowering the kiln temperature by manual control of the air vents (closing more number of air vents to regulate air entry there reducing the temperature developing inside the kiln).

Trial runs conducted at a lower carbonizing temperature range of 500⁰ C resulted with around 33% charcoal yield and 13% volatile content, 1.1% ash and 88.6 % fixed carbon. Trial run with a still lower temperature range of 350-400⁰ C yielded charcoal with a higher volatile content of around 20% desirable for use in the activation plant. This clearly shows the success of the newly developed vertical carbonizing charcoal plant for the production of charcoal desired for use as raw material for activated carbon production without compromising the Indian Standards for charcoal for industrial use.

9.3. Operation of Activation Plant

Place the water sealed product withdrawal can below the outlet pipe of activation plant before starting the activation process.

Load the activation plant with the pulverized charcoal of desired size through the feeding hopper. Switch on the air compressor and allow air at a pressure of around 2 kg/cm² to pass through the activation plant for half an hour before starting the ignition and maintain the same air pressure. Close the *steam inlet valve* of the reactor. Keep the steam bypass valve provided below the steam pressure gauge in open position for facilitating the indication of steam production.

Now, ignite the charcoal by putting some externally ignited burning crushed shells through the feeding hopper. Watch through the viewer glass and ascertain that the fire is getting stabilized. Because of the high quality air blow, the temperature slowly gets raised to above 800⁰ C.

It can be seen that steam is getting produced sufficiently in the waste heat recovery boiler when the temperature is reaching around 800⁰ C. Now, open the steam inlet valve and allow the steam to enter into the activation chamber. It can be observed that due to steam entry, the temperature is slowly falling down. Now, by regulating the steam entry by adjusting the steam inlet valve, adjust the system by trials in such a way that the steam entry is equilibrated against the maximum temperature attainable. At this stage, the steam pressure can be around 0.5 - 1 kg/cm² and

temperature around 900⁰ C. This is the stage where activation process is getting stabilized. Within a time of five hours after ignition, the system will get stabilized. The product withdrawn from this stage onwards is activated carbon.

Once the withdrawal can is filled up with activated carbon, then remove it from the outlet pipe and close it with its lid for a few minutes. Spread it over the dried floor, check for any fire or sparks, cool to room temperature and pack. Weigh the product for assessing the yield. The activated carbon can now be packed and stored for marketing.

It should be ensured that adequate water level is always maintained in the boiler. In case of a water level fall, the motor provided can be switched on for pumping water into the boiler. In case of negligence in keeping the water level and failure of NRV, the potential risk of return of high pressure steam to water pipes and tank and the resultant collapse of the structure can be prevented by immediately opening all steam relieving valves.

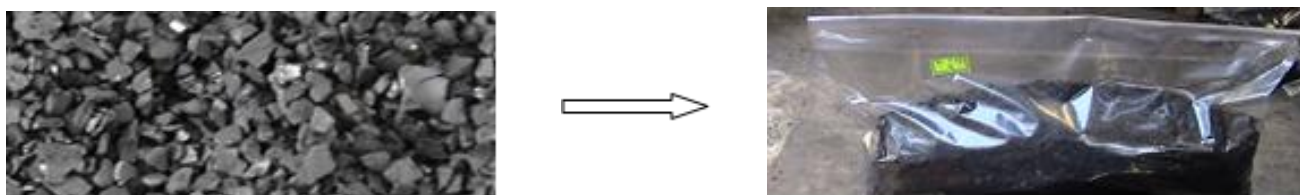

9.4. Quality of Granular Active Carbon produced in the newly developed RFBR Activation Plant

According to the Indian Standard Specification IS 2752 (BIS 1995) for granular activated carbons, the minimum requirement of iodine value (equivalent to the milligrams of iodine absorbed by one gram of active carbon of surface area between 900 and 1100 m²/ g, when the iodine concentration in the residual filtrate is at a concentration of 0.02 normal) is 900 mg/g for the ‘Type 1’ active granular carbons for use as a base for respirator carbons and solvent recovery and 450 mg/g for the ‘Type 2’ active granular carbons for the use in water treatment. The present product passes in this aspect (Table 2). In the case of surface area, another most important quality parameter of all absorbent materials, the surface area of granular active carbon produced is found well above the Indian Standard specifications of 550 to 900 m²/g (Table 2). This clearly shows that the newly developed RFBR is capable to produce granular active carbon of desired quality for the various industrial end uses.

Parameters	Mean Value
Moisture content (%)	2.0
Ash content (%)	2.0
Iodine value (mg/g)	1100
Surface area	900
Pore Volume (cc/g)	0.46-0.49

Table.2. Physical properties of the granular activated coconut shell carbon produced (n=9)

10. CONCLUSIONS

The defame in traditional charcoal production due to its associated pollution issue is tackled by developing a design of a continuous vertical carbonization plant devoid of ground level smoke-spread pollution and through the present investigation, the technology developed is further updated and up-scaled. Charcoal produced from the pilot plant have shown its capability to produce charcoal in better yield and desired quality for industrial use. Fluidized bed reactor (FBR) system has been identified as the alternative clean technology for small scale production of active carbon appropriate to community based organization (CBO) level is further updated and up-scaled to a rotary fluidized bed reactor (RFBR) plant. Quality of granular coconut shell carbon produced employing the newly developed RFBR activation pilot plant have shown its capability to produce granular active shell carbon in good yield, suitable for liquid phase industrial uses as per Indian Standards. The design and technology of both the plants were documented and are ready for commercialization. Analysis of economic feasibility has shown the strong potential of the up-scaled versions of the plants developed for commercial adoption.

11. SUMMARY

The design of the pollution-free continuous vertical carbonizing plant is with an input capacity of 3 tonne raw material (coconut shell) per day developed by KFRI in the earlier project supported by the Coconut Development Board (CDB) was up-scaled to an economically viable sustainable input capacity of 6 tonnes per day and further improved technically by incorporating a shell drier for pre-drying the raw material. The shell drier is designed for fitting above the carbonizer hood so that only dried shell will enter into the charcoal plant. This facilitates the use of slightly wet shells during the rainy season. The plant is successfully designed for targeted charcoal yield of around 30 per cent.

The design of vertical fluidized bed reactor (FBR) activation plant with an input capacity of 0.3 tonne shell charcoal per day developed by KFRI in the earlier CDB supported project was further improved to a horizontal rotary fluidized bed reactor (RFBR) for taking the technical benefit of high quality product coupled with cost effectiveness; the input capacity was up-scaled to 2 tonne shell charcoal per day, targeted for the standard (50%) active carbon yield.

Both the upgraded plants were successfully designed; fabricated and installed at CPCRI campus in Kasaragod, Kerala and trial runs were conducted. The process parameters were optimized for desired quality products and assessed the quality of products for industrial use. It was found that products from both the plants (shell charcoal and activated granular shell carbon) are conforming to the specifications of Indian Standards. The design drawings, description and operational details of the newly developed design upgraded up-scaled plants were documented. Both the plants are ready for further demonstrations to potential entrepreneurs and for use of the Community Based organisations (CBOs). The pollution-free technology appropriate for CBO level operations for the production of charcoal and granular activated carbon from coconut shells are ready to transfer for commercialisation.

As far as technical viability is concerned, scope exists for further improvements for automation for both carbonization and activation plants. Further scope also exists for developing appropriate technology for the CBO level production for impregnated active carbons for speciality purposes (e.g. silver impregnated granular active shell carbon) from the RFBR high grade active carbon produced. Both the pollution free plants produced are techno-economically appropriated for cluster or community level production of charcoal and activated carbon.

As the technical facilities of newly developed up-scaled charcoal plant facilitates better control over the temperature of carbonization and pollution aspects when compared with the traditional methods of production such as earth pit and homestead portable drum method. The newly developed system is found beneficial to the difficult-to sustain rural charcoal manufacturing industries. The technology developed is found appropriate as far as the quality of product is concerned, for the community level operations. Charcoal of desired quality can be produced by this technology for further value addition to activated carbon industries, thereby opening up a new avenue for better livelihood of the workers of the charcoal manufacturing cluster. Advantage of improved pollution control in the technology benefits the environment and the public health.

12. REFERENCES

- Albert Yehaskel 1978. Activated Carbon: Manufacture and Regeneration. Noyes Data Corporation. 329 pp.
- American Society for Testing and Materials (ASTM) 1977. Standard method for chemical analysis of wood charcoal. American National Standards ASTM D 1762-64 (Re-approved 1977). American Society for Testing and Materials, Philadelphia, Pa. p 577-579.
- Bureau of Indian Standards (BIS) 1984. Indian Standard IS: 1350. Methods of test for coal and coke (Part 1): Proximate analysis. Bureau of Indian Standards, New Delhi. 28 pp
- Bureau of Indian Standards (BIS) 1989. Indian Standards, IS 8366: Activated carbons, powdered - Specification. Bureau of New Delhi. 7 pp.
- Bureau of Indian Standards (BIS) 1992. Indian Standard Specification IS: 13522. Charcoal for explosives and pyrotechnic compositions - Specification. Bureau of Indian Standards, New Delhi. 6 pp.
- Bureau of Indian Standards (BIS) 1995. Indian Standard IS: 2752. Activated Carbons, Granular - Specification. Bureau of Indian Standards, New Delhi. 7 pp.
- Bureau of Indian Standards (BIS) 2002. Indian Standard IS: 877 - 1989 (Reaffirmed - 1999): Activated Carbons, Powdered and Granular - Methods of Sampling and Test. Bureau of New Delhi. 6 pp.
- Central Plantation Crops Research Institute (CPCRI) 2008. Value Chain in Coconut. National Agricultural Innovation Project Component 2: Research on Production to Consumption Systems. Project Profile. Central Plantation Crops Research Institute, Kasaragod.
- Clements, M. 2002. Granular activated carbon management at a water treatment plant. Magister *Ingenieriae* Degree Dissertation in Civil Engineering, Faculty of Engineering, Rand Afrikaans University.
- Cooney, D. O. 1980. Activated Charcoal: Antidotal and Medicinal Uses. Decker, New York.
- Dhamodaran, T. K. and Gnanaharan, R. 2008. Developing appropriate technology for community level production of charcoal and activated carbon from coconut stem wood and shell for industrial use. KFRI Research Report No. 347. Kerala Forest Research Institute, Peechi - 680 653, Kerala, India. 76 Pp.
- Estudillo, C.P., San Luis, J. M, Amio, E. C. and Tamolong, F. N. 1977. Charcoal production and utilization of coconut shells and trunk in the Philippines. *In*: Proseedings of the Coconut Stem Wood Utilization Seminar, Tonga, Ministry of Foreign Affairs, New Zealand. pp. 199 - 220.
- Foley, G. 1986. Charcoal making in developing countries. Technical Report No. 5. Earthscan - International Institute for Environment and Development, London. p. 214
- Gnanaharan, R and Dhamodaran T.K. 1988. Comparison of wilt-diseased and non-diseased (over-aged) coconut stem wood with respect to their utilization potential. Final Report of a Research Project sponsored by Coconut Development Board, Cochin, Kerala. Kerala Forest Research Institute, Peechi -680653, Kerala, India. 18 pp.

- Laine, J., Simoni, S. and Calles, R. 1991. Preparation of activated carbon from coconut shell in a small scale co-current flow rotary kiln. *Chemical Engineering Communications* 99 (1): 15 - 23.
- Loannidou, O. and Zabaniotou, A. 2007. Agricultural residues as precursors for activated carbon production - A Review. *Renewable and Sustainable Energy Reviews* 11 (9): 1966 - 2005.
- Manocha, M.S. 2003. Porous carbons. *Sadhana* 28 (1 & 2): 335 - 348.
- McDougall, G.J. 1991. The physical nature and manufacture of activated carbon. *Journal of the South African Institute of Mining and Metallurgy* 91 (4): 109 - 120.
- McDougall, G.J. and Hancock, R. D. 1980. Activated Carbons and Gold - A Literature Survey. *Mineral Science Engineering* 12 (2).
- Palomar, R.N. 1979. Charcoal Making. *In: 'Proceedings Coconut Wood - 1979'*. Manila and Zamboanga, Philippine Coconut Authority, Manila, Philippines. p. 176.
- Richolson, J. M. and Alston, A. S. 1977. Coconut palm stem wood charcoal, a potential source of heat energy for rural and peri-urban areas of Fiji. Part I. Production with simple steel drum kiln: Part II. Cooking with cast concrete charcoal stove. UNESCAP Regional Workshop on Biogas and other Rural Energy Resources. USP, Fiji, 20 June -July 1977.
- Satya Sai, P. M., Jaleel Ahmed and Krishnaiah.1997. Production of activated carbon from coconut shell char in a fluidized bed reactor. *Industrial and Engineering Chemistry Research* 36(9):3625 - 3630.
- Satya Sai, P. M. and Krishnaiah. 2005. Development and pore size distribution in the activated carbon produced from coconut shell char in a fluidized-bed reactor. *Industrial and Engineering Chemistry Research* 44 (1): 51-60.
- Stephen, F. T., Gardner, C.C., Nelson, A.J., and Marie, S.J. 1992. European Patent 0497154 A I (*cited from: Lartey, R.B. and Acquah, F. 1009. Developing national capability for manufacture of activated carbon from agricultural wastes. The Ghana Engineer. May 1999*).