

KFRI Research Report No. RR 561

ISSN: 0970-8103

**STRENGTHENING OF BAMBOO PRIMARY PROCESSING OF CENTRE AT KFRI**

**PHASE I**

**T. K. DHAMODARAN  
C. K. SOMAN**



**KSCSTE - KERALA FOREST RESEARCH INSTITUTE  
Peechi - 680 653  
Thrissur, Kerala  
India**



**2019 MAY**

KFRI Research Report No. RR 561

ISSN: 0970-8103

**STRENGTHENING OF BAMBOO PRIMARY PROCESSING CENTRE AT KFRI  
PHASE I**

**(Final Report of Project KFRI RP 681.8/2014)**

**(Funded by National Bamboo Mission)**

**Dr. T. K. DHAMODARAN**

**Dr. C. K. SOMAN**



**KSCSTE - KERALA FOREST RESEARCH INSTITUTE**  
**Peechi - 680 653, Thrissur**  
**Kerala, India**



**2019 MAY**

## 1. OUTLINE OF THE PROJECT PROPOSAL

*Code:* KFRI RP-681.8/2014

*Title:* Strengthening of Bamboo Primary Processing Centre at KFRI - Phase I

*Principal Investigator:* Dr. T. K. Dhamodaran

*Associate Investigator:* Dr. C. K. Soman

### **Objectives:**

1. Strengthen the Bamboo Primary Processing Centre (BPPC) established at FRC, Velupadam campus of KFRI with additional machinery required for downstream processing needs of bamboo for manufacture of bamboo products
2. Develop and implement management strategies for the sustainable running of the BPPC
3. Impart training to bamboo artisans in value addition through state - of - the -art interventions in product design and quality finishing and manufacturing bamboo products with high marketability
4. Capacity building of primary stakeholders for livelihood improvement by development of entrepreneurial and innovative skills and adapting to market trends.

### **Activities:**

1. Procure and install additional down-stream processing machines such as power loom for bamboo curtain blind making, Vacuum - pressure impregnation treatment facility, and a laser engraving machine for bamboo souvenir making as well as minor tools to compliment the installed machines for extending the range of products obtained from bamboo
2. Identify and develop linkages with appropriate agencies for the regular production-based running of the Centre.
3. Construct an additional work shed to install the machineries
4. Conduct training to artisans in product in value addition, design and finishing

*Tenure:* 1 Year (15<sup>th</sup> June 2014 to 14<sup>th</sup> June 2015)

*Budget:* Rs. 18.00 Lakhs

*Funded by:* National Bamboo Mission (NBM)

### **Outcome:**

1. A demonstration unit for mechanized primary processing of bamboo will be established for training and use by the traditional bamboo workers and artisans
2. Capacity building of artisan groups through training in manufacture of value added bamboo products with improved design and finishing for improved marketability
3. Diversified range of value added quality bamboo products with improved marketability will be available.

## 2. ACKNOWLEDGEMENTS

The financial support from the National Bamboo Mission is gratefully acknowledged. Sincere thanks are due to Dr. E. M. Muralidharan, NBM Project Coordinator in KFRI for the effective coordination between the various components and investigators of the entire project. Acknowledgements are due to Dr. T. M. Ganesh Gopal, Engr. Jino Johny and Shri. V. K. Sutteesh, Project Fellows of the Wood Science and Technology Division of KFRI for technical and field assistance and coordination. Also acknowledging the then Director, Dr. K. V. Sankaran and the present Director Dr. Syam Viswanath for their valuable leadership.

Also acknowledging M/s. Garnet Tools, Ujjain for supply and installation of the appropriate plant and machineries for the mechanical processing of local bamboos. Acknowledgements are due to the KFRI Scientists Dr. R. V. Varma (Rtd.), Dr. K. K. Seethalakshmi, Scientists (Rtd.), and Dr. V. B. Sreekumar, for editorial scrutiny for improving the quality of publication.

## STRENGTHENING OF BAMBOO PRIMARY PROCESSING CENTRE AT KFRI

### 3. PREFACE

KFRI has already established a Bamboo Primary Processing Centre (BPPC) with the support from the Annual Plan Programme of the National Bamboo Mission (NBM) of the Government of India. Mechanical processing being the basis for quality improvement as well as mass production for modern industrial scale operations and sliver based woven basketry mat products and related handicrafts production are found to be the local skills of the traditional artisan community, typical appropriate basic mechanical processing facilities were made available in the BPPC established in the earlier phase of the NBM project during 2012-'14. The present project aimed in further strengthening of the BPPC established in terms of added equipment's and machineries for facilitating the conduct of training programmes to the stakeholders. The strengthened BPPC is now open to the end use community. As *seeing is believing*, the present set up of the strengthened BPPC is helpful for motivating potential entrepreneurs as well as to provide training and demonstrations.

**Dr. Syam Viswanath**  
DIRECTOR  
KFRI

## STRENGTHENING OF BAMBOO PRIMARY PROCESSING CENTRE AT KFRI

### 4. CONTENTS

Sl. No.	Topics	Page
1	Outline of the Project Proposal	1
2	Acknowledgements	2
3	Preface	3
4	Contents	4
5	Abstract	5
6	Introduction	6
7	Activities	7
8	Achievements	10
9	Summary	12
10	References Cited	12
11	Appendices	13
11.1	Appendix. I. Details of Machines Installed & Suppliers	13
11.2	Appendix. II. Details of Trainings Conducted	13
11.3	Appendix. III. Photographs of Activities	14
11.4	Appendix IV. Detailed Design Drawings developed by the locally hired Master Craftsman and published in the website of NBM	16
11.4.1	<i>Puttukutty</i>	18
11.4.2	Flask	21
11.4.3	Hand-held Fan ( <i>Vishary</i> )	23
11.4.4	Box	25
11.4.5	Teapoy	28
11.4.6	Office Tray	30
11.4.7	Tissue Paper Box	32
11.4.8	Waste Paper Basket	34
11.4.9	Mobile Phone Holder	35
11.4.10	Other Products (Lamp shades, <i>Methiyadi</i> - chappal, <i>Valkannadi</i> - Hand-held Mirror, Pen Holder, Handicrafts, etc.)	36

## 5. ABSTRACT

Realizing the situation of non-availability of any local facility for training and demonstration on value-added utilization bamboo through mechanical processing in the State, a Bamboo Primary Processing Centre (BPPC) was established in KFRI during 2012-'14 through the financial assistance from the Annual Action Plan Programme of the National Bamboo Mission (NBM). It was further planned to strengthen the centre with more diverse machineries so as to facilitate the conduct of training and demonstrations to the relevant stakeholders. As the BPPC established already consists of the basic mechanical processing machineries for the primary processing of bamboo, viz., bamboo cross cutting machine, external knot removal - cum - skin removal machine, hydraulic splitting machine, internal knot removal - cum - skin removal machine, heavy duty slicing machine, and fine/thin slivering machine; the centre was further strengthened with a vacuum- pressure impregnation plant appropriate to industrial scale (mass) preservative treatment of bamboo, one power loom for bamboo curtain blind making and one laser engraving machine for bamboo souvenirs making by way of procuring and installing the facilities and by conducting successful trial runs. This was a step to convert the BPPC as a Common Facility Centre (CFC) with mechanical processing facilities for the primary as well as downstream processing of bamboo for product making.

Linkages were developed with the already existing local industries and interested NGO groups for running the centre and marketing the products. The BPPC established is thus further strengthened to a model self-sustainable bamboo primary processing centre with the Annual Plan Programme support of the National Bamboo Mission (NBM) of the Government of India. The centre is designed to be capable for conducting training and demonstrations for strengthening the bamboo utilization sector through the inputs from KFRI as well as for the local livelihood improvement by way of employment generation in the bamboo sector as a future model. Training programmes of various durations were provided to school students, vocational course aspirants and undergraduate students in Forestry in bamboo processing.

**Key Words:** Bamboo primary processing, bamboo mechanical processing, bamboo processing machineries, bamboo preservative treatment, bamboo seasoning, bamboo products.

## 6. INTRODUCTION

A Bamboo Primary Processing Centre (BPPC) was established in the Field Research Centre (FRC) campus of KFRI at Velupadam during 2012-'14 with the initially identified appropriate mechanical processing facilities (bamboo cross cutting machine, external knot removal - cum - skin removal machine, hydraulic splitting machine, internal knot removal - cum - skin removal machine, heavy duty slicing machine, and fine/thin slivering machine) (Dhamodaran *et. al.*, 2019). Considering the scope of expansion of the BPPC established for future purposes on training and demonstrations in the value-added bamboo utilization sector, the centre was found in need of further strengthening in terms of other diverse down-stream processing facilities too for providing training and demonstrations to the needy stakeholder community.

As bamboo being a perishable material, enhancement of durability of bamboo products warrants the prime concern. Due to this reason, it was planned to procure and install a preservative treatment plant capable of demonstrating the treatment of mass quantity of bamboo required for industrial scale operations in bamboo-based enterprises that are supposed to emerge in future. A bamboo vacuum-pressure impregnation (VPI) treatment plant is suggested for the effective commercial/industrial scale preservative treatment of this '*perishable, but difficult to treat*' material.

As far as the bamboo-based industries of the adjoining locality of the BPPC is concerned is found dominated with traditional bamboo hand loom curtain blind units, it was planned to introduce a power loom for the purpose of demonstrations on the latest state - of-the-art to potential entrepreneurs. Also, it was suggested to procure a laser engraving machine ideal for demonstrations in bamboo small souvenir production.

It was also envisaged to develop and implement managerial strategies for the effective running of the strengthened BPPC and to impart training to bamboo artisans in value addition through the state - of - the art interventions in product design and quality along with the manufacturing of finished products of high marketability as a part of capacity building of primary stakeholders for livelihood improvement by development of entrepreneurial and innovative skills and adapting to market trends. It was planned to hire the assistance of a local Bamboo Master Craftsman for design and skill development improvement aspects as well as for leading the vocational trainings envisaged.



## 7. ACTIVITIES

The need of proper space was felt as the immediate concern to properly house the major machineries procured under a single roof, for convenience of efficient usage and management as a single unit. Actions were undertaken to construct a new work shed of approximate area of 1500 sq. ft.

The locality of the Field Research Centre (FRC) of KFRI at Velupadam, Thrissur District, Kerala where the Bamboo Primary Processing Centre (BPPC) is established was found enriched with the traditional bamboo artisan community, '*Sambavas*'. The proximity of the FRC and the bambusetum established there and the marginalized traditional bamboo working backward community ('*Sambavas*') in the region led a preliminary informal survey among the community to assess their skills and livelihood situation so as to take appropriate decision on the direction of strengthening the BPPC in terms of the identification of the additional facilities needs to be developed and the scope of strengthening the proposed BPPC in improving their livelihood through value-added utilization of their livelihood material, bamboo.

The KFRI- Bamboo Technology Support Group (BTSG) Scientists' group meetings were conducted for arriving at conclusions for deciding the bamboo products target and for identifying and selecting the additional introduction of the diverse down-stream bamboo processing machineries in the BPPC established, as a part of the strengthening works.

Accordingly, as a part of value-addition, developing facilities for the permanent preservative treatment of bamboo (as bamboo being a perishable material of difficult to treat nature) was identified as the prime concern for the time being which will facilitate the offering of training in this line to impart durability to bamboo products thereby fetching more marketability, price for products and sustainability of the enterprises for achieving livelihood improvement, at least partially. A Vacuum Pressure Impregnation Plant (VPI) appropriate for the commercial/industrial scale handling of mass quantity of bamboo ('*Garnet*' brand) was procured and installed. The treatment chamber was of length 10 feet and diameter 2 feet attached with the usual vacuum and pressure pumps and the preservative chemical storage tank.



V P I Treatment Plant

Considering the dominance of the region in traditional bamboo curtain blind manufacturing units employing traditional hand loom machines, a 6 feet power loom with 2 HP motor (*Garnet*) was introduced as a progressive step to motivate industrial entrepreneurs in innovative modern techniques.



Power Loom



Bamboo Curtain Blind

Bamboo souvenir manufacturing had the potential to utilize small offcut sections of the treated raw material as well as had scope in marketability in eco-tourism/nature conservation related field. Due to this reason, the innovative modern technique of laser engraving was introduced in bamboo souvenir making. A computer system attached the MY-L 3040 model Laser engraving machine of 60 W Laser tube with CO<sub>2</sub> Laser generator, 300 x 400 mm up/down platform bed with rotary facility for using round bamboo sections, capable of engraving the input designs in bamboo sections was procured and installed for the purpose.



Laser Engraving Machine & Engraved Souvenir Products



Another informal survey on the existing bamboo based industries and bamboo consuming public sector undertakings in the locality helped significantly in identifying and developing the potential linkages for production and marketing of the products that could emerge from the proposed BPPC and also to develop appropriate strategies for the sustainable operation of the enterprise that is going to be established. Accordingly, an established NGO group in the region interested in the utilization of eco-friendly natural materials like bamboo, 'AVARD' (Apex Voluntary Agency for Rural Development) was identified for the running the BPPC and to market the products. An MoU in this regard was entered on mutual agreement basis and an employee-friendly remuneration package to the workers were satisfactorily implemented by the NGO, AVARD. The bamboo slivers produced employing the mechanical production facilities established was agreed to take by a local industrial cooperative society engaged in traditional bamboo curtain blind manufacture having good market linkage. A self-sustainable model BPPC was thus initiated to exist.

Group work, Survey, observation, motivation classes and periodic monitoring and evaluation of the feedback received from the community were used as the tools for achieving the target of utilizing the BPPC for the livelihood betterment of the marginalized bamboo working community of the locality.

Trial runs of the down-stream bamboo processing machines installed were conducted successfully. The strengthened BPPC was thus commissioned. The Centre is opened for future training and demonstrations to artisans, interested skill groups/NGOs, etc. for the promotion of the value-added utilization of bamboo for livelihood substance of the traditional artisan communities as well as to modern industrial entrepreneurs.

The service of a local Bamboo Master Craftsman was hired for an initial period of 6 months to work for developing improved designs for local products. It was planned to publish the design drawings in the website of NBM. Trainings of various durations (5 days, 7 days, 10 days and 1 month duration) were conducted (lead by the Master craftsman and a team of expert trainers from other recognized institutions) for the benefit of interested groups such as vocational and undergraduate students, Kudumbasree workers, etc.

## 8. ACHIEVEMENTS

- Identified M/s. HABITAT TECHNOLOGIES, Thiruvananthapuram, Kerala as the right architectural consultant and builder for the construction of a permanent work shed of approximate area of 1500 sq. feet (permissible within the allotted budget and compromising to the space requirements of the machineries to be installed) employing cost effective method of construction, to house the bamboo mechanical processing machineries in ambient proper spacing. The civil construction work was completed and occupied by mid-2015.
- The survey among the marginalized bamboo working communities of the Velupadam area revealed that the *Sambava* community at Velupadam had the traditional skill of producing bamboo mat based products and the prevailing socio-economic situation (invasion of plastic materials) inhibit them to be away from using bamboo as their livelihood material. It was convinced that introduction of value-addition techniques and the primary as well as down-stream mechanical processing facilities of the strengthened BPPC established can bring back their livelihood through improved utilization of bamboo.
- Linkages were developed with a traditional bamboo curtain blind manufacturing unit ('*Seraphic* Bamboo Industrial Cooperative Society', Velikulangra, Thrissur) and a leading NGO (AVARD, Chalakkudy, Thrissur) involved in livelihood improvement activities of the poor and marginalized backward communities and entered into a MoU. Accordingly, it was agreed that AVARD will manage the BPPC which will produce slivers and *SERAPHIC* will utilize the slivers for curtain blind manufacturing as a stop gap arrangement for the time being. This was materialized as a part of the project activities on scientific interventions to support existing bamboo industries. KFRI thus got strengthened the BPPC for onward demonstration to potential entrepreneurs and trainees in bamboo utilization and to carry forward its future research in the area along with regular production. The BPPC is administered under the Wood Science and Technology Division of KFRI. Sustenance of enterprises bringing livelihood improvement in the traditional bamboo artisan sector is found capable to achieve through the model approach developed and established.
- Promotional activities such as introduction of free uniforms to working women are made by the NGO associated. An appropriate remuneration system was also introduced satisfactorily to the NGO management controlled by the Institute.

- The services of a Bamboo Master Craftsman was made available to the Centre for an initial period of 6 months in order to develop improved designs of local bamboo products for better marketing and livelihood improvement.
- As the informal survey on industrial bamboo products manufacturing in the locality revealed that bamboo curtain blind production is the major end product in many established units, the introduction of power loom could be a potential further step to secure sustainability and quality of products in the local bamboo-based industries engaged mainly in traditional mat based curtain blind manufacture. Trial runs for the production of bamboo slivers was made successfully.
- Bamboo souvenir manufacture was a potential area capable of utilizing even small sized bamboo sections. Visitor mind strategy also favors souvenir industry due to reasons of convenience to handle and carry, easy transportability in terms of production end, aesthetics, and low cost concerns. Regional themes could be easily and quickly incorporated in the souvenir items by way of simple screen printing or by the application of laser engraving technique for better aesthetic value. Appropriately engraved pictures or logos in the bamboo souvenir are found having enhanced marketability. Laser engraving facility is found having great potential for improved aesthetics, fetching high prices. Design preferences of the consumers can be quickly adaptable in bamboo souvenir production by this innovative modern technique employing computer based software and laser beams for engraving.
- The details of the new machines installed and their suppliers are given in Appendix I.
- Work Experience Training, Vocational Training, and Advanced Trainings were given to School students, vocational students and undergraduate students in Forestry and Kudumbasree members. Trainings were given to about 70 persons within a year (see Appendix II & III).
- The BPPC is opened for future use (training & demonstrations to traditional bamboo artisans and industrial entrepreneurs/interested NGO groups. The BPPC is proposed to upgrade into a strengthened self-sustainable bamboo common facility centre (CFC) through the NBM-KFRI Action Plan for 2015-'16.
- The design drawings and relevant details were published through the website of NBM for the benefit of entrepreneur stakeholders. A copy of the text of the same is given in Appendix IV. Drawings of improved designs of local bamboo products published were open to all entrepreneurs.

## STRENGTHENING OF BAMBOO PRIMARY PROCESSING CENTRE AT KFRI

### 9. SUMMARY

The Bamboo Primary Processing Centre (BPPC) established at the Field Research Centre (FRC) of KFRI at its Veluppadam campus in an available work shed appropriated for the purpose was further strengthened by way of (i) providing a large spaced work shed to conveniently house the major machines under a single roof for better management and (ii) by way of introducing diverse machines for the further downstream processing of bamboo for product manufacture. Based in informal surveys on the local skills and the nature of existing industrial units on bamboo products, availability of treated material being found to be a major hurdle in producing value added products of improved durability, vacuum-pressure impregnation (VPI) treatment facility appropriate for adaption in commercial/industrial bamboo enterprises was introduced. Bamboo products with enhanced durability are found fetching higher prices and improved marketability thereby helpful in achieving livelihood improvement.

Introduction of innovative modern techniques such as power loom for the production of bamboo curtain blinds manufacture and laser engraving technology for bamboo souvenir making lead to the motivation of entrepreneurs in the respective fields.

Arrangements were made to manage the running of the establishment by an interested NGO (*AVARD*) working locally and marketing linkages were developed with a local cooperative society based curtain blind manufacturing unit (*SERAPHIC*) to utilize the slivers produced by the mechanical facilities established, as model. The set up developed is found compatible for the livelihood improvement of the local socially backward traditional bamboo working community '*Sambavas*'; that too especially concentrating on the local working class women empowerment, as the major employment generated was found to be occupied by women of the '*sambava*' community. The products are marketed through the NGO associated. Thus a model self-sustainable bamboo processing and product manufacturing initiative capable for the later training and demonstrations in bamboo utilization sector was effectively established for the time being. Assistance of a Master Craftsman was made available for developing improved designs of local products for publication purpose and the designs were published in the website of National Bamboo Mission (NBM). Trainings were provided to the needy community; trainings of varying duration such as 5 days, 7 days, 10 days, 1 month, etc. were provided to a total of around 70 persons within a year. Further assistance from the future plan programmes of the Institute and the NBM are under pipeline for the further strengthening of the Centre as well as the conversion of the same to a Common Facility Centre (CFC).

### 10. REFERENCE CITED

Dhamodaran, T. K. Muralidharan, E. M., Raveendran, V. P. and Soman, C. K. 2019. Establishment of a centre for primary processing of bamboo at KFRI. Final Report of a Project (KFRI RP 647.6/2012) supported by National Bamboo Mission, GOI. Kerala Forest Research Institute, Peechi - 680 653, Kerala, India. 17 pp.

## 11. APPENDICES

### 11.1. Appendix I. Details of Machines installed & Suppliers

Sl. No.	Machine	Details of Supplier	Cost (Rs. In Lakh) (In 2014)
1	VPI Treatment Plant, with control panel, pressure controllers and setting device; length of treatment cylinder 10 feet, diameter 2 feet. <i>GARNET</i> Brand	M/s. Garnet Tools 2-D, Industrial Area, Ujjain Road Dewas, Madhya Pradesh	4.73
2	Bamboo Curtain Blind making Machine, with 2 HP Motor, <i>Garnet Brand</i>	Pin: 455 001; Ph:07272 228719 E-Mail: <a href="mailto:info@garnetindia.com">info@garnetindia.com</a> Website: <a href="http://www.garnetindia.com">www.garnetindia.com</a>	6.53
3	Laser Engraving Machine, MY-L 3040 x 400 mm Up/Down bed with Rotary arrangement, 60 W Laser (CO <sub>2</sub> ) Tube, HIWIN/PMI Guide Rails, Leads Shine Drive/Motor	M/s. RPM Tools Consulting 49/671, Halifax Lane, Elamakkara, Kochi - 682 026 Ph: 0484 2409030; 0422 2684656 (Coimbatore Office) Mobile: 9567486396/9543349454 E- Mail: <a href="mailto:consult@rpmtools.in">consult@rpmtools.in</a> Website: <a href="http://www.rpmtools.in">www.rpmtools.in</a>	3.94

\* Cost including packing, forwarding, insurance, transportation, installation, trial runs & commissioning charges

### 11.2. Appendix II. Details of Trainings Conducted

Sl. No.	Training Details	No. of Participants	Remarks
1	Work Experience Training - <i>One Month Training in October 2014</i> . Master Craftsman: Shri. Parameswaran Kalloor, Thrissur, Ph: 9961835870	5	Training students to undertake the making of bamboo products in Work Experience Competitions
2	Vocational Training - <i>One Week Training, 19-25 Aug. '14</i>	9	Training in making of various products like <i>Puttukutti</i> , Flask, etc.
3	Advanced Training: <i>5 Days Bamboo Product Making Training to Under Graduate Forestry Students 11-15ov. '14</i> .	13	Preservative Treatment & Seasoning, Product making
4	10 Days Training on Bamboo Crafts for Livelihood to <i>Kudumbasree</i> Members of Varandarappilly Panchayath, Thrissur District, Kerala <b>Trainers:</b> Mr. Antoney, Cheenikkal, URUVU, Wayandu, Ph: 9446951459. Mr. Krishnan, C., Thenkurushy, Palakkadu, Ph: 9497124423. Mrs. Tatha Krishnan, W/o. Mr. Krishnan, C., Thenkurushy, Palakkadu, Ph: 9497124423) & Mr. Vincent, S., V. B. Handicrafts, Thiruvananthapuram, Ph: 9745167280.	43	Training included one Day Exposure Trip to KSBC Bamboo Ply-Board Factory at Angamaly & Another One Day Exposure Trip to <i>URUVU</i> , Wayanadu.
<i>Total No. of persons trained:</i>		70	

### 11.3. Appendix III. Photographs of Activities







**11.4. Appendix IV. Detailed design drawings developed by the locally hired Master Craftsman and published in the website of NBM**

**BAMBOO CRAFT PRODUCTS FROM THE KFRI BAMBOO PRIMARY PROCESSING CENTRE**

**Designs and Specifications**

The livelihood options of the bamboo dependent communities in the last several decades had undergone a decline due to the non-availability of raw material and lack of marketing avenues for the traditional bamboo products. The newer generation had moved away from this sector and the traditional craft was slowly fading out. The Bamboo Primary Processing Centre (BPPC) was established in the Institute as a means of reviving this sector by demonstrating the benefits of mechanized primary processing of bamboo to artisans and farmers. The value addition and improvement in efficiency and quality of production of articles made of bamboo was expected to contribute significantly to reviving the traditional industry and make it a sustainable livelihood option for all involved. The BPPC can also act as a CFC for the industry for generating primary processed bamboo raw material like poles, split bamboo and slivers for various end products.

A general appraisal of the nature of bamboo products made traditionally in the region and those which still found a ready market were selected for the purpose of reviving an activity involving traditional artisans and introducing mechanised primary processing for value addition. A clear preference is still shown for products that are categorised as eco-friendly and products from bamboo, rattan, coir and coconut shell would still find a market. Enabling the artisans to take the benefit of mechanisation in reducing the drudgery and improvement of quality, was expected to make such a bamboo based venture a sustainable livelihood option.

As a first step in initiating the programme, a list of products based on bamboo was prepared which was within the skill levels of the selected artisans after giving a preliminary training. Raw material was provided from the clumps in the FRC, Velupadam and bamboo reeds procured from the Kerala State Bamboo Corporation, Angamaly. The details of the bamboo based products, the design and specifications are given in the following pages.

### 11.4.1. PUTTUKUTTY

#### (STEAMED RICE CAKE MAKER)

'*Puttu*' (*Malayalam*) is a steamed rice preparation that is popular in South India. This breakfast preparation is traditionally made with lightly fried medium to coarse powdered rice which is moistened and kneaded by hand before being filled into the Puttumaker. Wheat (*Aata/Rava*), Corn, Ragi, etc. can also be used in the place of rice.

The *puttkutty* commonly used these days consists of metal cylinder with provision for attaching it on the mouth of a larger vessel in which water is boiled to generate steam. A lid with vents is provided on the top of the steamer. The cooking is complete when steam is found coming out at the top. The cooked food in the shape of a cylinder is pushed out by the use of a small thin cylindrical rod.

Traditionally the *puttukutty* was made of bamboo and there is a preference for bamboo since it perceived as healthier and imparting a better taste.

*Puttu* in smaller quantities is also prepared in a vessel made of a half of coconut shell. The vessel is placed with the holes (eyes) of the shell over the steaming vessel. A hemispherical *puttu* is thus made.

#### Raw materials

Cylindrical Bamboo culm sections, half cut coconut shell sections, coir rope and glue

#### Tools required

Cross cutting machine, sand paper/sander, Electric / hand drill.

#### Manufacturing process

Round bamboo having suitable medium diameter needs to be selected, cut into suitable length (an internode with the node included at the lower part and the top being open) and air dried. The outer and inner surfaces of the bamboo piece needs to be polished well using sand paper and cleaned out thoroughly. The coir rope is tightly



wound over one-third portion at the lower half of the bamboo cylinder in order to provide grip for holding and also to prevent subsequent cracking of bamboo over the service period. A hole of suitable diameter is made with the help of a drill in the centre of the septum at the nodal region in order to enable placing the cylinder above the steaming vessel or the vent of a pressure cooker so that steam passes un-hindered into the puttumaker. A perforated disc (metallic or made up of a flat disc made of coconut shell) is provided which is placed at the bottom of the cylinder just above the septum so as to retain the rice powder filled in it.

The *Puttukutty* can be made compatible for use with kitchen vessel used for generating the steam (*Puttukudum*, in *Malayalam*) or with a pressure cooker by making small appropriate alterations at the bottom. A small hollow piece of bamboo glued to the nodal region may also be used, if necessary, to guide the steam into the bamboo cylinder. The small bamboo piece should properly fit on the pressure cooker nozzle. A coconut shell of appropriate size with two holes on it acts as a cap to the puttu maker and as a steam vent. A rounded stick made of bamboo could be used to push the sieve and the steamed *puttu* out of the *puttukutty*.

The cost of production of the bamboo *puttukutty* is comparatively low since the raw materials are readily available and the manufacturing processes are simple. The market price of a bamboo *puttukutty* is around Rs. 100/- per piece. This does not include the boiling vessel /pressure cooker which is available in most of the local shops.

### PUTTUKUTTY- SECTIONAL ELEVATION

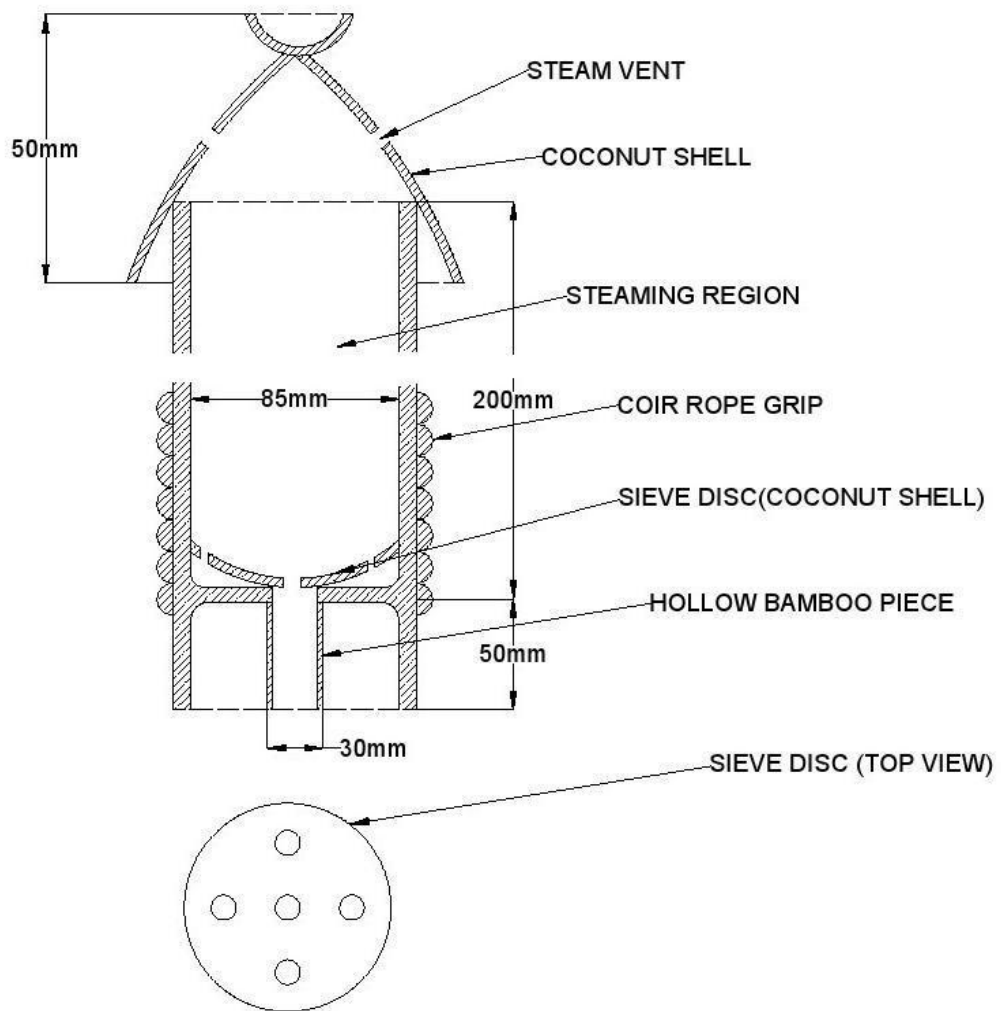

### 11.4.2. FLASK

Bamboo flask is a simple eco-friendly economy thermos flask that can be made using raw materials that are readily available. A glass bottle (beer or wine bottle) and piece of round bamboo culm are the main raw materials required to make this natural flask. This flask is found capable of maintaining the temperature of liquids stored in it for sufficiently long time.

#### Raw materials

Glass beer bottle, bamboo, coir rope, glue, saw dust, etc.

#### Tools required

Cross cutting machine, sand paper/sander and knife

#### Manufacturing process

The glass beer bottle selected for making flask is first thoroughly cleaned. A fully dried bamboo culm having an inside diameter of at least 5mm greater than that of the outside diameter of the glass bottle is selected for making natural flask. The bamboo piece is to be cut to the desired length as shown in the figure. The outer and inner surfaces of the bamboo are to be smoothed using sand paper and cleaned.



The glass bottle is to be inserted into the round cylindrical bamboo culm section. Insulating material such as saw dust, cotton wool, etc. needs to be filled evenly around the gap between bamboo culm and the bottle. The tapered neck of the bottle that projects above the bamboo cylinder is to be covered with thin slivers of bamboo glued together to cover the taper neck up to the bottle mouth. A coir rope is then wound over the pieces of bamboo as shown in the figure so as to cover the portion and to provide sufficient grip to the bottle and improve the aesthetic look of the product.

A cap is to be made with a solid bamboo stem section which tightly fits the bottle mouth. The body of the flask can be decorated by mounting bamboo strips using glue as shown in the photograph.

The cost of production is low since the raw materials are readily available and the manufacturing procedure is simple. The bamboo natural flask is expected to fetch a price of around Rs. 100/- per piece.

The efficiency of the natural bamboo flask could still be improved by replacing the glass bottle with a vacuum flask refill and providing appropriate modifications to prevent breakage due to impacts.

# BAMBOO FLASK- SECTIONAL ELEVATION

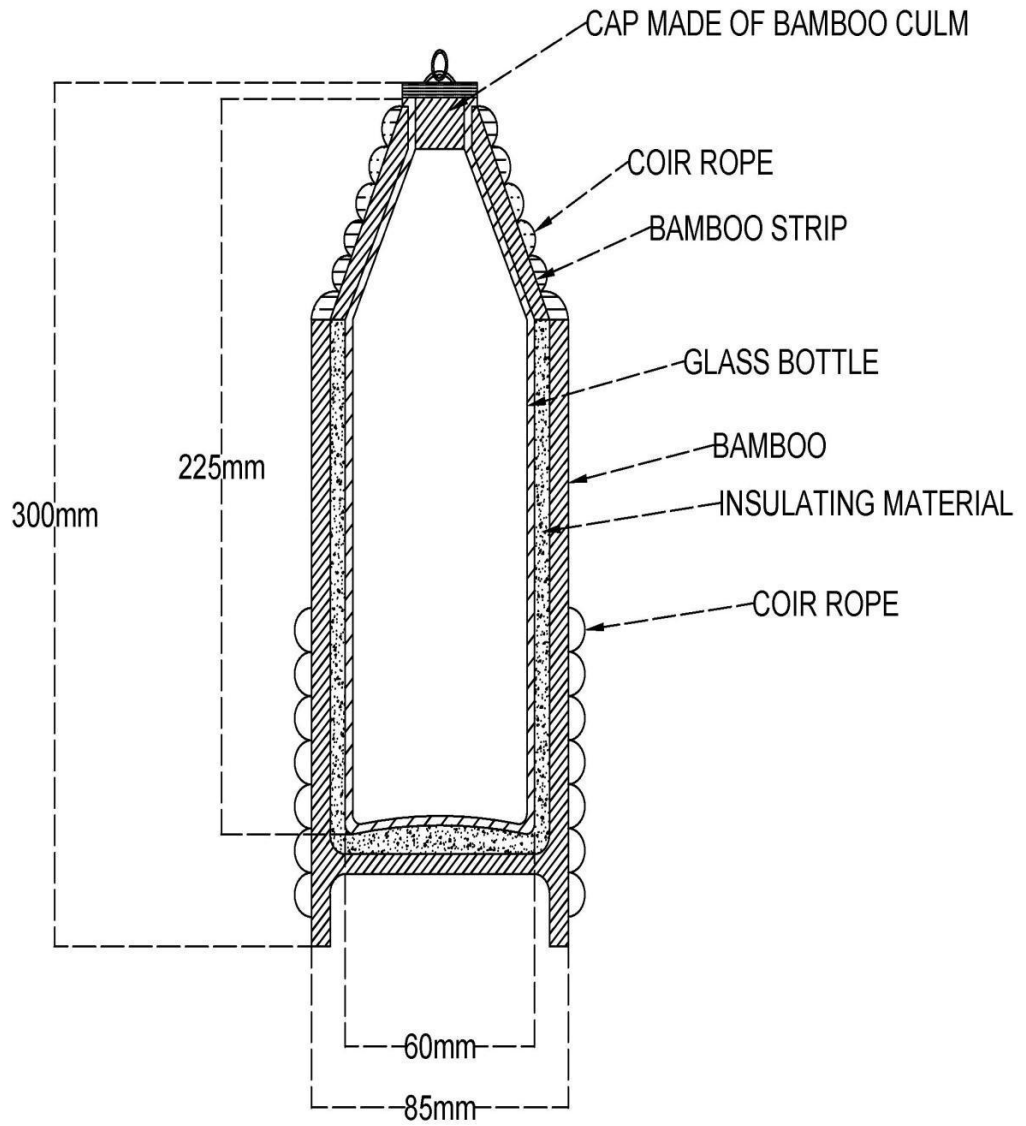



### 11.4.3. HAND-HELD FAN (VISHARY)

Bamboo fan is a bamboo craft product what incorporates an innovative design. The hand-held fan is used to induce a gentle air flow for the purpose of refreshing oneself. This fan is a modification of the traditional fan designs where instead of the rigid flat blade fixed on the handle, the modification enables the blade to revolve smoothly on the handle. The fan blade is made of a woven bamboo mat cut to shape and fixed on a small length of hollow bamboo culm which in turn revolves around the axis made of a bamboo culm of smaller diameter which forms the handle. The fan takes advantage of the varying diameter and wall thickness of different bamboo and reed bamboo species.

#### Raw materials

Bamboo, synthetic glue, fabric thread etc.

#### Tools required

Hacksaw, knife, needle.

#### Manufacturing process



The bamboo fan is a combination of a small woven bamboo mat attached to a handle. The mat is made by weaving thin slivers of bamboo in order to reduce weight of the fan. The mat is cut to specific shape as shown in the figure. The mat is strengthened by pasting length of thick fabric trim along the edges.

The mat is then attached to a hollow bamboo piece of 60 mm using synthetic glue and fabric thread as shown in the figure. A longer bamboo piece of 275 mm having a lower outer diameter than the hollow bamboo piece is selected as handle for the fan. The hollow bamboo piece with the mat blade is inserted over the top portion of the handle and held in place by two stoppers made of short lengths of hollow bamboo that fits tightly above and below the blade, as shown in the figure, so that it can rotate freely on the handle. By moving the handle the fan will rotate and induce airflow.

The aesthetic value of the fan can be increased by colouring, varying the weaving patterns, using embroidery works, etc.

# DESIGN DRAWING OF BAMBOO FAN

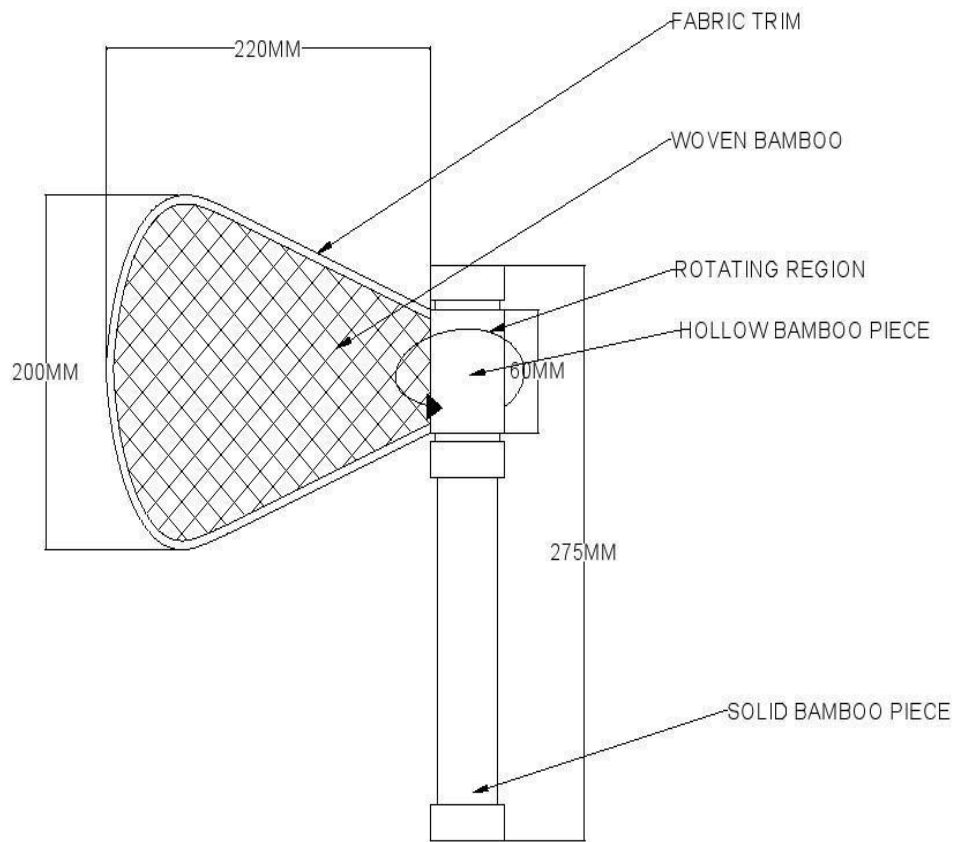

#### 11.4.4. JEWELLERY BOX

Bamboo box is a small receptacle almost entirely made up of bamboo. It can be an elegant substitute to plastic/metal boxes that serve as container for reading glasses, jewellery, cosmetics, etc. Bamboo box is more attractive than normal plastic boxes due to its natural look.

##### Materials required

Bamboo culm, glue, muslin cloth, etc.

##### Tools required

Cutting machine, sanding machine, Hacksaw, Knife, etc.

##### Manufacturing process

A piece of bamboo culm of suitable size is selected for making bamboo box. The bamboo is cross cut at the internodal region and again split along its length to equal halves using cutting machine. The inner and outer surfaces of the bamboo are smoothed using sander.



The hinges to join the two parts of box can also be made up of hollow bamboo culms of very small diameter. Two hollow pieces and a peg of solid bamboo are required. The hinges are made by joining these pieces by using glue as shown in the figure. The handle for the bamboo box is made up of cylindrical bamboo pieces. The locking mechanism for the bamboo box is also made up of bamboo culm in the same manner. The box is provided legs consisting of two long pieces of bamboo attached to the bottom of lower half along its length

The box can be coloured to increase its aesthetic value. An inner lining of muslin/velvet cloth can be added to the interior of the box to provide aesthetic appeal. The bamboo boxes can made as an acceptable alternative to cartons and plastic containers used to pack various articles particularly those that are marketed as organic produce or herbal cosmetics.

**BAMBOO JEWELLERY BOX- FULLY OPEN (TOP VIEW)**  
*(All dimensions are in mm)*

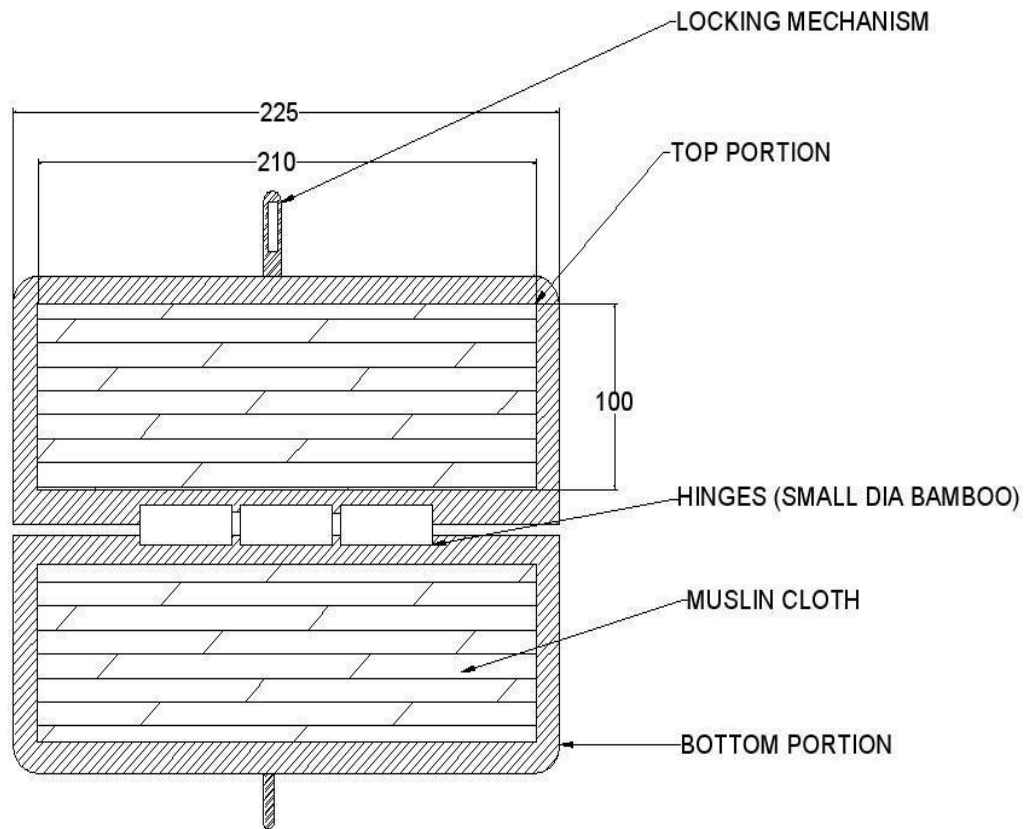

**JEWELLERY BOX**  
**SIDE VIEW**  
*(All dimensions are in mm)*

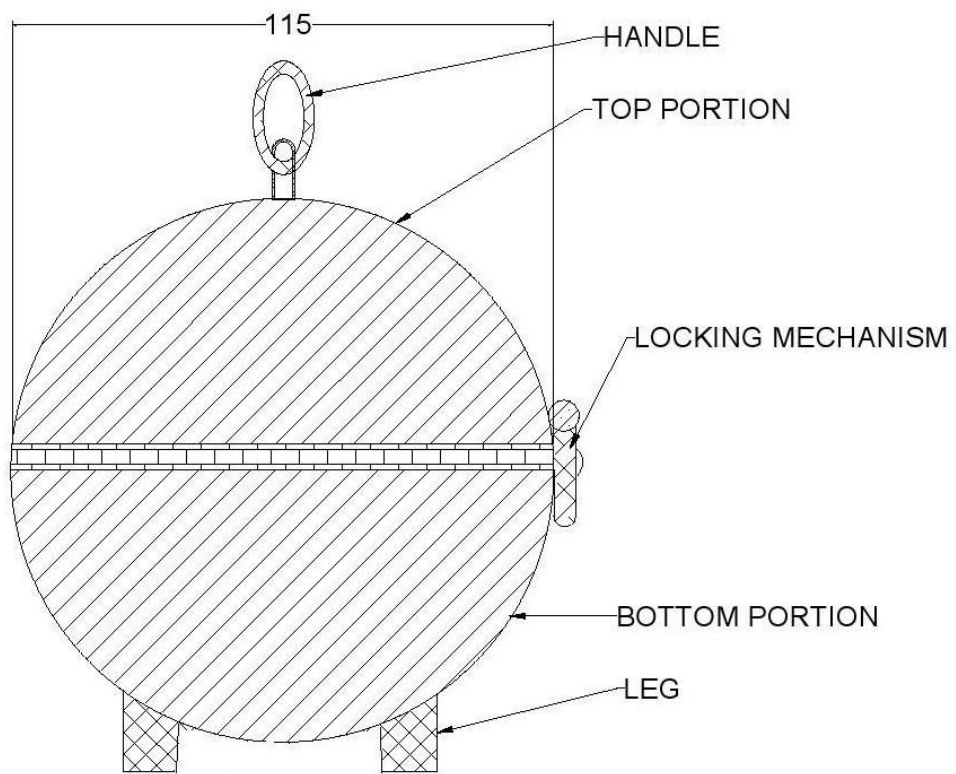

#### 11.4.5. TEAPOY

Bamboo tea-poy is a tea-poy that is entirely made up of bamboo which is comparatively economical. Bamboo tea-poy looks more natural than the plastic tea-poy. The manufacturing processes are also simple in the case of bamboo tea-poy.

##### **Raw materials**

Treated bamboo

##### **Tools required**

Cross cutting machine, splitting machine, sander / sand paper, drilling machine, thick slivering machine, hack saw, etc.

##### **Manufacturing process**

Treated bamboo with 150mm diameter is cut to 600mm length for making the leg of the tea-poy. Split bamboo pieces are made to thick slivers using thick slivering machine. Two rows of thick bamboo slivers are joined using bamboo nails. The top portion of the tea-poy is smoothed using sander and sand paper. The cylindrical culm and four thick split bamboo pieces which supports the top are joined together by using nails made up of small bamboo pieces. The base portion is made by joining split bamboo pieces together and forming a rigid square shaped base. The base and the culm are joined together using bamboo nails. The whole tea-poy is then smoothed using sand paper. Applying paint on the tea-poy will add its aesthetic value.



**BAMBOO TEAPOY**  
**SECTIONAL DIAGRAM**  
*(All dimensions in mm)*

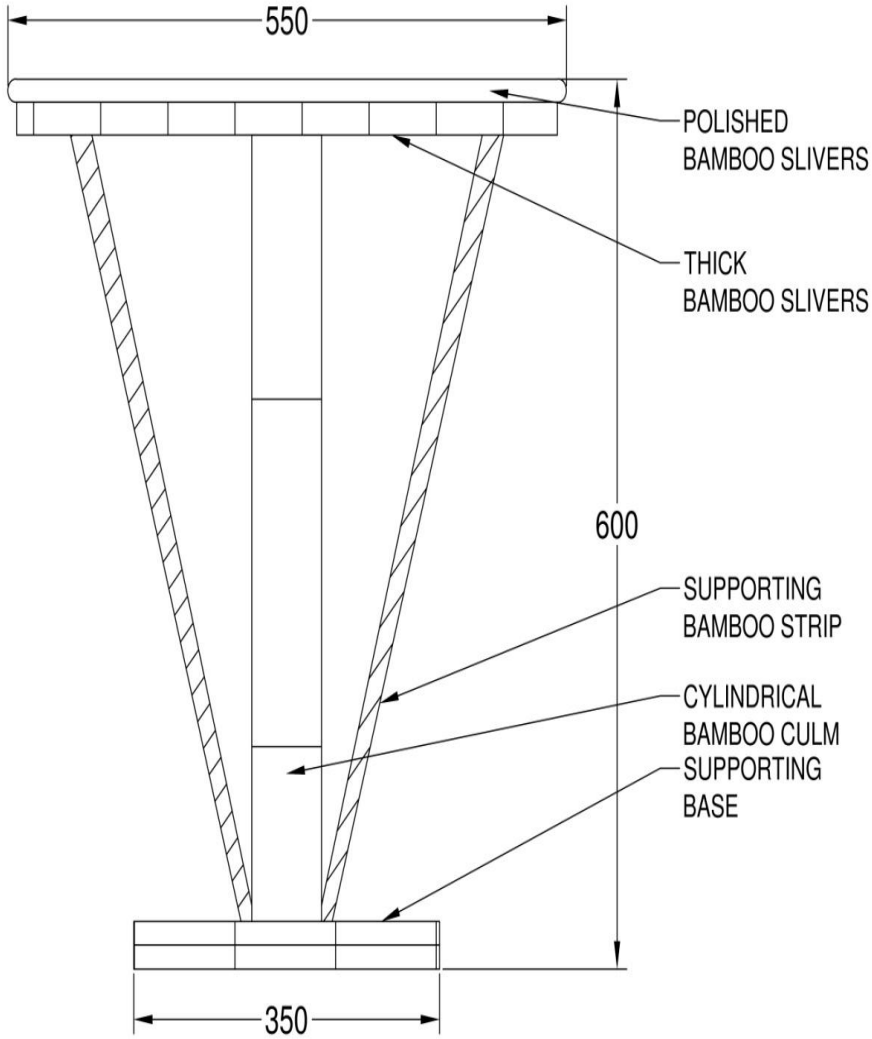

#### 11.4.6. OFFICE TRAY

Bamboo tray is an economical serving tray which is almost fully made up of bamboo. It is economical since the raw material used here is bamboo and manufacturing processes are comparatively simpler. Bamboo trays are more eco-friendly and have a natural look when compared to plastic and metal trays. Bamboo trays can also be easily made out of waste bamboo pieces.

##### **Raw materials**

Treated bamboo and glue.

##### **Tools required**

Cross cutting machine, splitting machine, sander, drilling machine and hack saw.

##### **Manufacturing process**

Treated bamboo having internodal length of 200mm or more is selected for making bamboo tray. Bamboo is to be splitted into pieces and the nodes are to be removed. The inner and outer surfaces of the split pieces are smoothed using sander and sand paper. The base portion of the tray is made up of four thick split bamboo pieces. Two of the pieces are of 350mm and the remaining two are of 200 mm in length. The pieces are to be joined to the base portion using bamboo nails as shown in the figure. The nail portions are then smoothed using sander. The two side portions of the tray are then cut from cylindrical bamboo culms. The handle portions are also cut from cylindrical bamboo culms and shaped using hacksaw and sander. The side portions and the handle portions are then joined to the initially made base and inner portion using bamboo nails and synthetic glue. The whole tray is then smoothed and polished to get a smooth finish.





**BAMBOO TRAY- TOP VIEW**  
(All dimensions in mm)

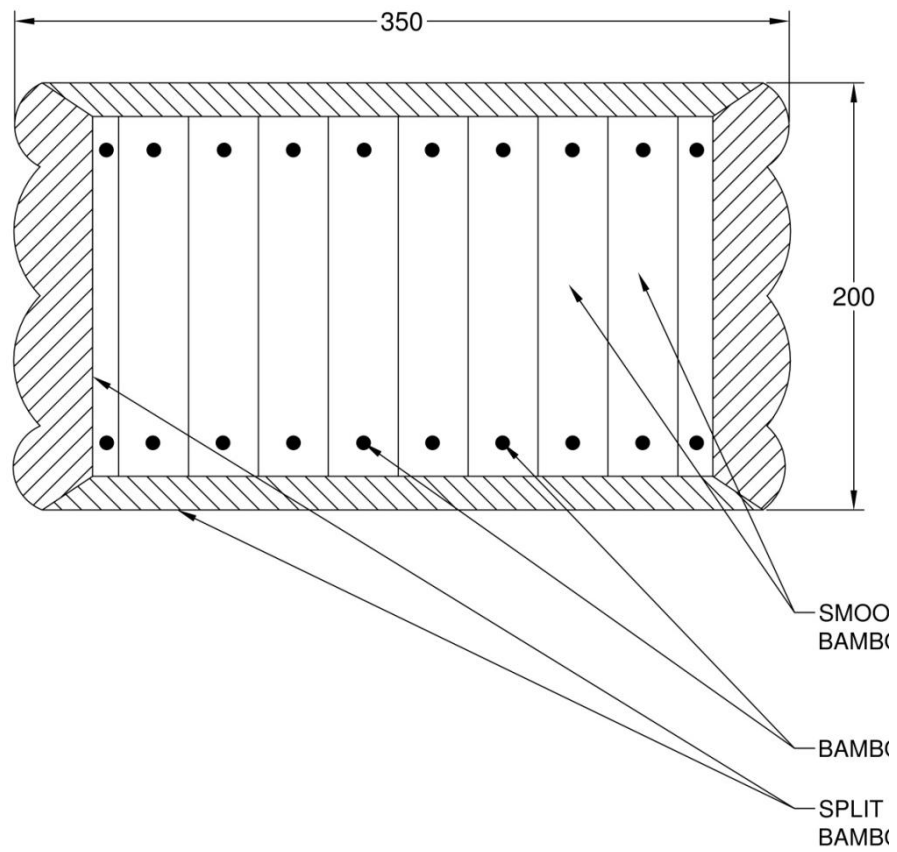

**SIDE VIEW**

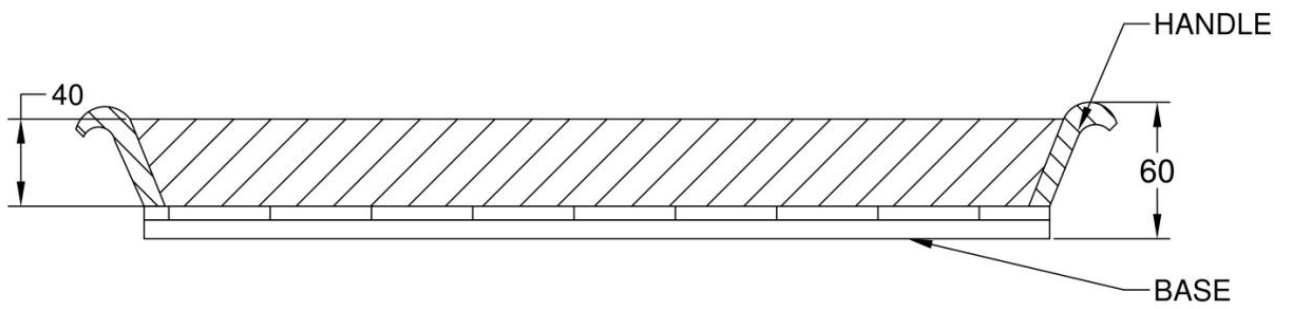

#### 11.4.7. TISSUE PAPER BOX

This tissue paper box is typically made up of bamboo. Almost all the parts are of bamboo. It must be an alternative for costly plastic as well as metal tissue paper boxes now available in market. Bamboo tissue paper boxes can be made easily and it is economical also. It has more aesthetic value when compared to plastic tissue paper boxes.

##### **Raw materials**

Treated bamboo and glue.

##### **Tools required**

Cross cutting machine, splitting machine, slivering machine, sander, hacksaw and knife



##### **Manufacturing process**

A treated cylindrical bamboo piece is cut to 200 mm length without nodes. The outer and inner surfaces are then smoothed and polished using sandpaper and sander. Bamboo slivers are made using thick slivering machine from split bamboo pieces. The cap portion is cut out of the surface of the cylinder as per the required dimensions using hacksaw and knife. The edges are then smoothed using sandpaper. The slivers are then attached to the side portion of the hollow bamboo culm using glue. The hinges which join the cap and the culm are made up of small hollow bamboo pieces and glue as shown in the figure. The locking mechanism cut out of bamboo is joined to the cap using glue. The leg or base portion of the box cut out of bamboo culm is also joined to the cylinder using glue. The whole box is then smoothed using sandpaper. Attaching thin slivers to the surface of the box will add the beauty of the box. Painting or polishing can also be done to improve the aesthetic value. Thus the bamboo tissue paper box is made.

**TISSUE PAPER BOX- TOP VIEW**  
 (Dimensions in mm)

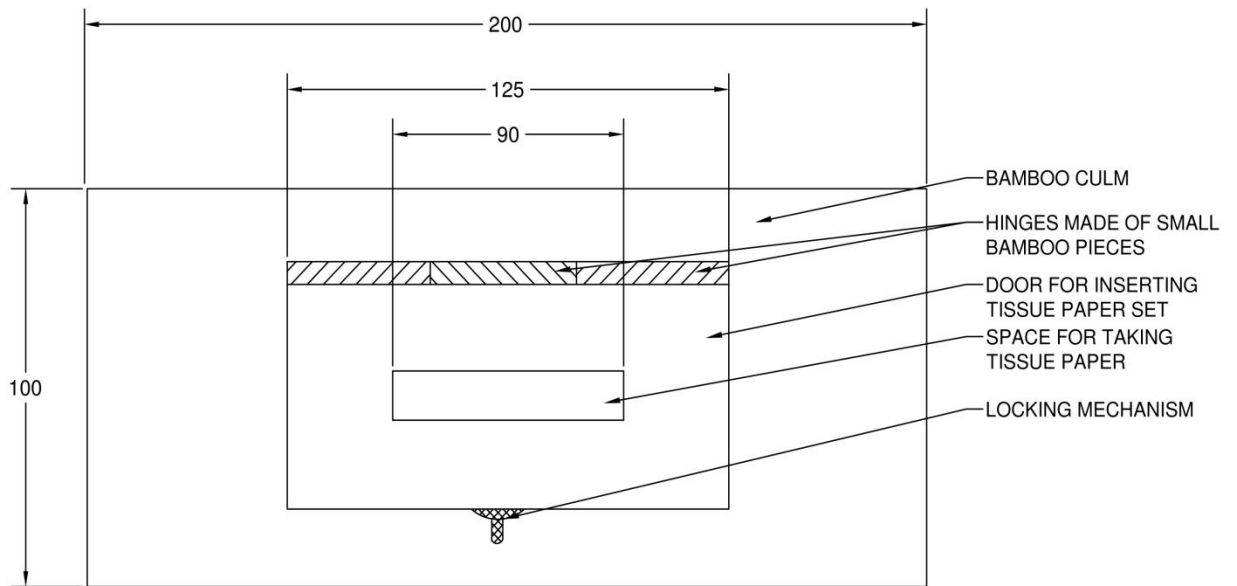

**TISSUE PAPER BOX- SIDE VIEW (CAP OPEN)**

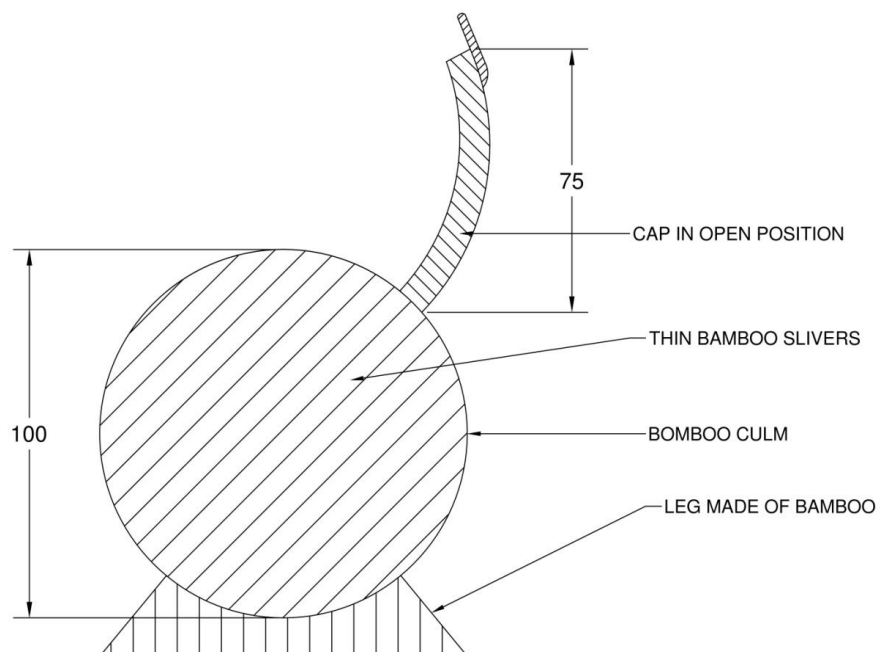

#### 11.4.8. WASTE PAPER BASKET

Waste paper baskets are an indispensable utensil in houses, offices, industries, etc. Plastic waste paper baskets of various shapes, sizes and models are now available in market. The same can be replaced with the eco-friendly material, bamboo. Bamboo waste paper baskets look more pleasing and natural than plastic and metal baskets.

##### Raw materials

Treated bamboo and glue.

##### Tools required

Cross cutting machine, splitting machine, slivering machine, sander, hack saw and knife.

##### Manufacturing process

Treated bamboo pieces are to be splitted using splitting machine and cut to the required dimension, *i.e.*, height of the basket. Two ring one upper and one lower is made using thick bamboo slivers and glue. The upper ring should have bigger diameter than the lower ring. The split bamboo pieces are attached to the two rings using bamboo nails to form a vertical rib like structure as shown in the figure. This gives shape to the basket. The base portion of the basket is made up of bamboo slivers. The slivers are joined together using glue to form a rigid flat surface. This base is then attached to the lower ring portion using bamboo nails. The strength and beauty of the basket can be improved by weaving thin slivers on the ribs of the basket. The gap between the ribs can also be closed, if not much gap is desirable.



#### 11.4.9. MOBILE PHONE HOLDER

Mobile phone holders can be easily manufactured using bamboo with minimum expenditure. It is cost effective and are eco-friendly.

##### **Raw materials**

Treated bamboo and glue.

##### **Tools required**

Cross cutting machine, sander, hacksaw and knife.

##### **Manufacturing process**

Treated bamboo culm is cut to small pieces which constitute the parts of the mobile phone holder as shown in the figure. The dimensions of the front and side pieces should be a bit lesser than the length of a typical mobile phone. The back portion should be lengthier than the remaining three portions. This back portion constitutes the wall hanging region. The base portion should be flat enough to be seated properly. The whole portions are joined together using glue and then sanded for smooth finish. Surface decorations and painting can improve the beauty and value of the product. Pen holders, brush holders, etc. can also be made in a similar way.



## 11.4.10. OTHER PRODUCTS

### LAMP SHADES



### METHIYADI (Chappal)



### VALKANNADI (Hand-held Mirror)



PEN HOLDER



HANDICRAFTS

